

# freud<sup>®</sup>

Made in Italy

CATALOGUS ZAAGBLADEN



2003

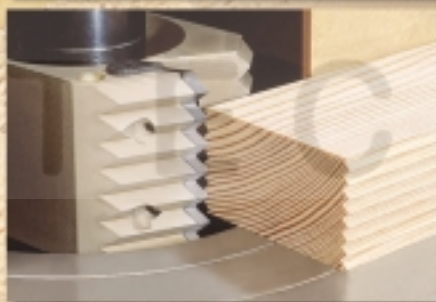
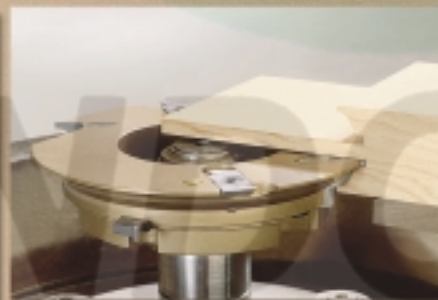

#### FELETTO UMBERTO (UD)

Kantoren, productie van standaard en speciaal frezen.  
Offices, production of standard and special cutterheads.



#### FAGAGNA (UD)

Productie van zaagbladen.  
Sawblades production.



#### MARTIGNACCO (UD)

Productie hardmetaal.  
Production and sintering of hard metal.



#### COLLOREDO DI M. ALBANO (UD)

Productie van bovenfrezen.  
Production of router bits.



## TRADITIE EN TECHNOLOGIE

- > Om te kunnen voldoen aan de steeds hogere eisen voor houtbewerkingsgereedschappen, zijn een hoge kwaliteitsstandaard en vooruitschrijdende technologie onontbeerlijk.
- > FREUD, sinds langer als 40 jaar leidinggevend in deze sector, biedt oplossingen voor iedere vraag
- > FREUD is gespecialiseerd in de productie van hm cirkelzaagbladen (met een jaarlijkse productie van meerdere miljoenen stuks), frezen voor kozijn-en deurproductie, bovenfrezen en hardmetaalproducten, zoals keermessen en zaagtanden.
- > De eigen hardmetaalproductie kan inspelen op de optimalisering van de verschillende hardmetaalsoorten voor ieder produkt.
- > FREUD beschikt over een wereldwijd vertakt handelsnetwerk en wordt daarom op alle grotere beurzen vertegenwoordigd: Interbimall-Milaan, Eisenwarenmesse-Keulen, Tekhnoles-St. Petersburg, Ligna-Hannover, NHS-Chicago, IWF-Atlanta, Int. Woodw.Mach. -Peking.

# freud®

## TRADITION AND TECHNOLOGY

- > Responding with efficiency and timing to needs all the more specific in the production of woodworking tools, it is essential that we apply the most advanced technology in order to guarantee absolute reliability and quality.
- > FREUD, a leader in this field, has been offering specialized solutions to satisfy any possible requirement for more than forty years.
- > FREUD Pozzo is specialized in the construction of circular saws (the number of sawblades manufactured each year alone is estimated at around several million), tools for the construction of window and door frames, brazed and mechanically mounted tips and a whole range of carbide inserts, sawblade tips and disposable knives all constructed in Hard Metal.
- > Our very own production of HARD METAL guarantees the possibility to improve the grade of hardness in correspondence to the kind of work with which the tool has been designed to undergo.
- > To give everybody the possibility to recognize the FREUD mark, the company is present at all the leading woodworking exhibitions all over the world: at Milan (INTERBIMALL-XYLEXPO) at Cologne (DYTEC INTERNATIONALE EISENWARENMESSE), at Saint Petersburg (TEKHNOLLES) at Sydney (AWISA), at Hannover (LIGNA) at Chicago (NHS-NATIONAL HARDWARE SHOW), at Atlanta (IWF - INTERNATIONAL WOOD-WORKING FAIR) at Pecking (INTERNATIONAL WOODWORKING MACHINERY).

# DIT MAAKT VAN DE FREUD ZAAGBLADEN EEN SUPERIEUR KWALITEITS-ZAAGBLAD

## HERE'S WHY FREUD SAWBLADES ARE A SUPERIOR QUALITY PRODUCT



### Anti kick-design

Nieuwe spaanbegrensdende vorm waardoor hogere mate van veiligheid, reduceert gevaarlijke terugslag bij te hoge aanvoersnelheid. Maakt het zaagblad uitermate geschikt voor het bewerken van hout met noesten en mindere kwaliteiten spaanderplaat.

### Anti kick-design

New shoulder design for added safety, reduces dangerous kickbacks given by overfeeding making the sawblade good at cutting wood with lose knots, nails and poor quality chipboard.

Verleent de carbide tanden een maximale standtijd bij extreem hoge vereisten.

### Tri-metal brazing

Allows carbide tips to withstand extreme impact for maximum durability.

### Tri-metal brazing



### Laser cutting

Freud's zaagbladen worden allen met laser gefabriceerd.

### Laser cutting

Freud's sawblade bodies are exclusively cut by laser.

De uniforme korrels zijn een essentiële vereiste voor een strakke zaagsnede en een lange standtijd.

### Micro-graine carbide

Verhoogt de standtijd.

The uniformity of the grit is essential to achieve the correct cutting qualities and long life characteristics.

### Micro-grain carbide

Increases a carbide's resistance to abrasion.

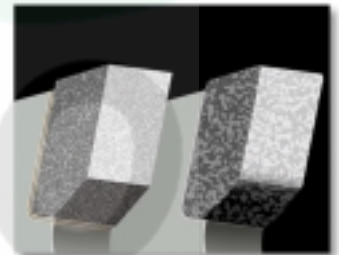

### Expansie sleuven

Verminderen de spanning van het zaagblad bij hoge temperatuur en middelpuntvliedende kracht.

### Expansion slots

Dissipate blade stress over a greater area given by high temperatures and centrifugal forces.

De geluidsarme zaagbladen hebben dempers, voorzien van een speciaal materiaal, ter vermindering van geluidsoverlast.

### Geluidsarme zaagbladen

The low noise sawblade has sound dampening slots filled with a special material in order to reduce vibration whilst in use.

### Low noise sawblades



### Tuning ring

De tuningring wordt aangetroffen op de meeste Freud zaagbladen en geeft het zaagblad een strakkere zaagsnede.

### Tuning ring

The tuning ring can be seen on most Freud sawblades as a faint ring line about 2/3 the diameter of the blade and renders the sawblade more rigid during rotation.

# LU01M

## HM SCHULP- EN AFKORTZAAGBLAD WISSELTAND T.C.T. RIPPING SAWBLADES



STANDAARD STANDARD GELUIDSARM LOW NOISE permaSHIELD

ART.	D mm	B/b mm	d mm	Z	LU01 M	LU01M SS	LU01M T
LU01M AB3	200	3,2 / 2,2	30	24	€ 38,73		
LU01M EB3	250	3,2 / 2,2	30	30	€ 43,52		
LU01M FC3	300	3,2 / 2,2	30	36	€ 52,89		
LU01M GB3	350	3,5 / 2,5	30	42	€ 72,82		
LU01M GD3	350	3,5 / 2,5	35	42	€ 72,82		
LU01M HB3	400	3,8 / 2,8	30	48	€ 94,00		
LU01M KA3	500	4,2 / 3,2	30	60	€ 176,11		

> Zaagblad voor het langzagen van hard en zacht hout met een maximale zaaghoogte van 50mm en voor spaanplaatmateriaal met een dikte van 60 - 100 mm.  
Te gebruiken op tafelzaagmachine.

> Sawblade for ripping with medium finish on softwoods and hardwoods with maximum thickness of 50 mm and single or multiple chipboard panels up to 60-100 mm.  
Use on table saw.

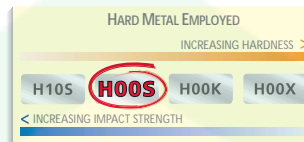
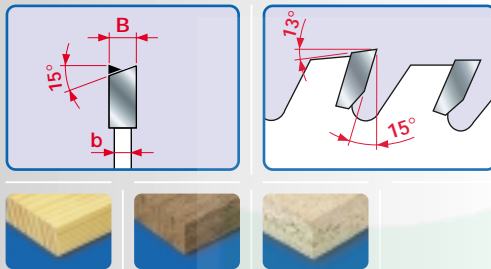

# LU02M

## HM SCHULP- EN AFKORTZAAGBLAD WISSELTAND T.C.T. SAWBLADES FOR RIPPING AND CROSS CUTTING



STANDAARD STANDARD GELUIDSARM LOW NOISE permaSHIELD

ART.	D mm	B/b mm	d mm	Z	LU02 M	LU02M SS	LU02M T
LU02M AB3	150	3,2 / 2,2	30	24	€ 31,50		
LU02M BB3	180	3,2 / 2,2	30	30	€ 38,22		
LU02M BC3	180	3,2 / 2,2	35	30	€ 38,22		
LU02M CB3	200	3,2 / 2,2	30	34	€ 42,87		
LU02M CC3	200	3,2 / 2,2	35	34	€ 42,87		
LU02M DA3	220	3,2 / 2,2	30	34	€ 48,03		
LU02M GB3	250	3,2 / 2,2	20	40	○		
LU02M GC3	250	3,2 / 2,2	30	40	€ 50,24	€ 55,40	
LU02M GD3	250	3,2 / 2,2	35	40	€ 50,24		
LU02M PB3	275	3,2 / 2,2	30	42	○		
LU02M HC3	300	3,2 / 2,2	30	48	€ 61,67	€ 73,03	€ 67,87
LU02M HE3	300	3,2 / 2,2	35	48	€ 61,67		
LU02M IC3	350	3,5 / 2,5	30	54	€ 79,02	€ 97,61	€ 87,28
LU02M IE3	350	3,5 / 2,5	35	54	€ 79,02	€ 97,61	
LU02M KC3	400	3,8 / 2,8	30	60	€ 101,23	€ 116,20	
LU02M KE3	400	3,8 / 2,8	35	60	€ 101,23		
LU02M LC3	450	4,0 / 3,0	30	66	€ 159,07	€ 183,34	

> Zaagblad voor het schulpen en afkorten van hard en zacht hout met een maximale zaaghoogte tot 50 mm. Formaatzagen van spaanplaatmateriaal tot 60 mm. Te gebruiken op tafelzaagmachine.

> Sawblade for ripping and cross cutting with medium finish on softwoods and hardwoods up to 50 mm and single or multiple chipboard panels up to 60 mm. Use on table saw.

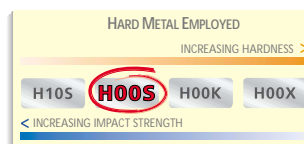
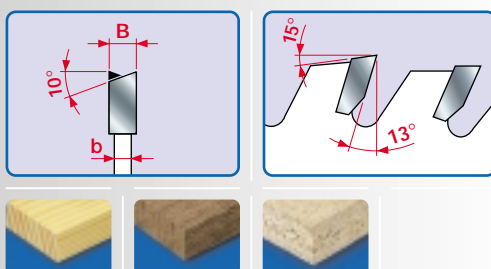

# LU04M

## HM UNIVERSEEL ZAAGBLAD WISSELTAND T.C.T. SAWBLADES FOR RIPPING AND CROSS CUTTING

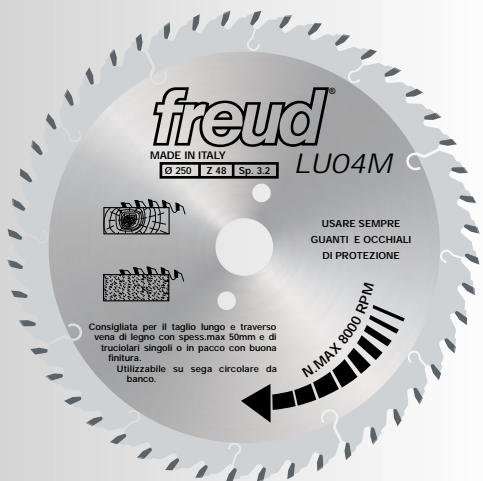

STANDAARD STANDARD    GELUIDSARM LOW NOISE    permaSHIELD

ART.	D mm	B / b mm	d mm	Z	LU04 M	LU04M SS	LU04M T
LU04M DB3	250	3,2 / 2,2	30	48	€ 52,05		
LU04M EB3	300	3,2 / 2,2	30	60	€ 64,25		
LU04M FB3	350	3,5 / 2,5	30	72	€ 78,50		

- > Zaagblad voor het schulpen en afkorten van zacht en hard hout, tot maximaal 50 mm zaaghoogte. Bij spaanplaatmateriaal met een maximale zaaghoogte van 60 mm. Te gebruiken op tafelzaagmachine.
- > Sawblade for ripping and cross cutting of softwoods and hardwoods up to 50 mm and single or multiple chipboard panels up to 60 mm with good finish. Use on table saw.

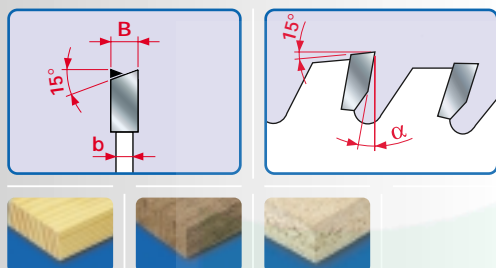

COD.	α
LU04M DB3	13°
LU04M EB3	10°
LU04M FB3	10°

HARD METAL EMPLOYED

INCREASING HARDNESS >

H10S **HOOS** H00K H00X

< INCREASING IMPACT STRENGTH



# LU06M

## HM UNIVERSEEL ZAAGBLAD WISSELTAND T.C.T. SAWBLADES FOR CROSS CUTTING



STANDAARD STANDARD    GELUIDSARM LOW NOISE    permaSHIELD

ART.	D mm	B / b mm	d mm	Z	LU06 M	LU06M SS	LU06M T
LU06M AB3	180	3,2 / 2,2	30	42	€ 45,45		
LU06M BB3	200	3,2 / 2,2	30	48	€ 45,45		
LU06M DC3	250	3,2 / 2,2	30	60	€ 57,99	€ 68,83	€ 63,67
LU06M DD3	250	3,2 / 2,2	35	60	€ 57,99		
LU06M PA3	275	3,2 / 2,2	20	60	○		
LU06M EC3	300	3,2 / 2,2	30	72	€ 70,97	€ 82,33	€ 78,20
LU06M EE3	300	3,2 / 2,2	35	72	€ 70,97		
LU06M FC3	350	3,5 / 2,5	30	84	€ 93,48	€ 111,55	€ 103,29
LU06M FE3	350	3,5 / 2,5	35	84	€ 93,48	€ 111,55	
LU06M GC3	400	3,8 / 2,8	30	96	€ 119,82	€ 133,76	

- > Zaagblad voor het afkorten en formaatzagen van zacht, hard en exotisch hout, ook pakketgewijs. Te gebruiken op tafelzaagmachine.
- > Sawblade for cross cutting of softwoods, hardwoods, and exotic woods up to 60 mm with excellent finish. Also, use for single or multiple chipboard panels. Use on table saw.

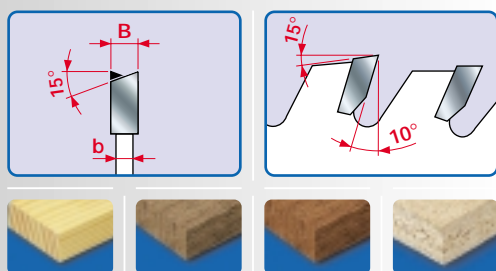

HARD METAL EMPLOYED

INCREASING HARDNESS >

H10S **HOOS** H00K H00X

< INCREASING IMPACT STRENGTH



# LU09M

## HM UNIVERSEEL ZAAGBLAD WISSELTAND T.C.T. THIN KERF SAWBLADES FOR CROSS CUTTING



STANDAARD STANDARD GELUIDSARM LOW NOISE permaSHIELD

ART.	D mm	B/b mm	d mm	Z	LU09 M	LU09M SS	LU09M T
LU09M AB3	150	2,0 / 1,4	30	48	€ 41,32		
LU09M BB3	180	2,0 / 1,4	30	56	€ 45,45		
LU09M BD3	180	2,0 / 1,4	40	56	€ 45,45		
LU09M CB3	200	2,2 / 1,6	30	64	€ 51,65		
LU09M DB3	250	2,5 / 1,8	20	80	€ 66,76		
LU09M DC3	250	2,5 / 1,8	30	80	€ 66,76	€ 83,81	
LU09M EC3	300	2,7 / 1,8	30	96	€ 83,36	€ 99,89	
LU09M FC3	350	3,0 / 2,2	30	108	€ 106,91	€ 123,43	

- > Afkortzaagblad voor harde en exotische houtsoorten met een maximale zaaghoogte tot 50 mm. Voor een en tweezijdig met kunststof beklede panelen tot 50 mm zaaghoogte en voor kunststof als PVC en Resopal tot 10 mm zaaghoogte.
- > Sawblade for cross cutting with excellent finish on hardwoods and exotic woods up to 50 mm and laminated panels one side only up to 30 mm. For cutting with medium finish formica sheets and PVC up to 10 mm. Use on table saw. Thin kerf requires less horse.

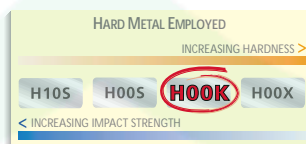
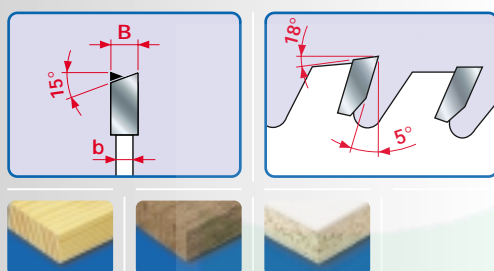

# LU10M

## HM UNIVERSEEL ZAAGBLAD WISSELTAND T.C.T. THIN KERF SAWBLADES FOR CROSS CUTTING



STANDAARD STANDARD GELUIDSARM LOW NOISE permaSHIELD

ART.	D mm	B/b mm	d mm	Z	LU10 M	LU10M SS	LU10M T
LU10M AB3	150	3,2 / 2,2	30	48	€ 42,87		
LU10M BB3	180	3,2 / 2,2	30	56	€ 54,23		
LU10M CB3	200	3,2 / 2,2	30	64	€ 56,29		
LU10M DA3	220	3,2 / 2,2	30	64	€ 57,84		
LU10M EB3	250	3,2 / 2,2	30	80	€ 68,83	€ 85,87	€ 76,06
LU10M FC3	300	3,2 / 2,2	30	96	€ 86,46	€ 97,31	€ 95,24
LU10M FE3	300	3,2 / 2,2	35	96	€ 86,46		
LU10M GB3	330	3,5 / 2,2	20	96	€ 105,36		
LU10M HC3	350	3,5 / 2,5	30	108	€ 107,42	€ 124,47	€ 118,27
LU10M IC3	400	3,8 / 2,8	30	120	€ 139,44		

- > Afkortzaagblad voor harde en exotische houtsoorten met een zaaghoogte tot 60 mm. Voor dubbelzijdig kunststof beklede panelen tot 30mm zaaghoogte en kunststofplaten, zoals PVC en resopal tot 10 mm. Te gebruiken op tafelzaagmachine.
- > Sawblade for cross cutting with excellent finish on hardwoods and exotic woods up to 60 mm and laminated panels on one side only up to 30 mm. For cutting with medium finish of formica sheets and PVC up to 10 mm. Use on table saw.

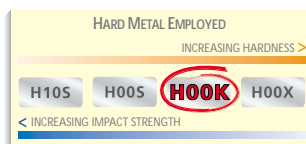
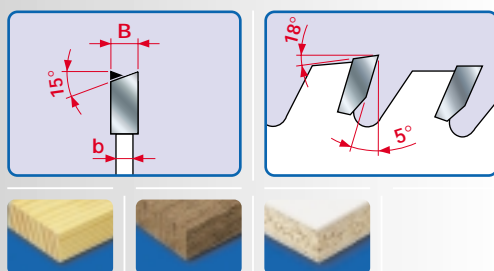

# LA91M

## HM FORMAATZAAGBLAD WISSELTAND

### T.C.T. SAWBLADES FOR CUTTING LAMINATED PANELS

STANDAARD  
STANDARD

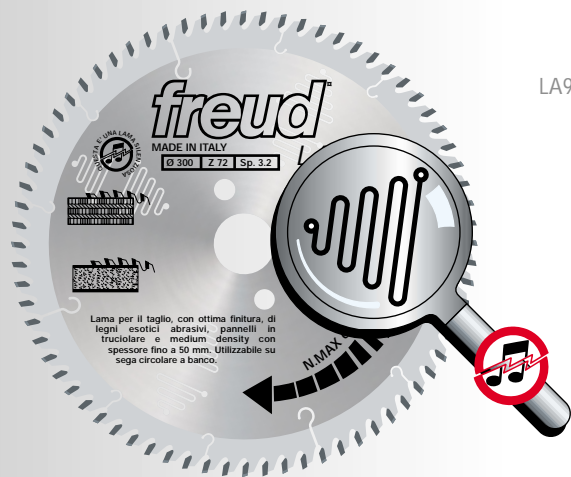

ART.	D mm	B/b mm	d mm	Z	LA91 M	
LA91M 001	300	3,2 / 2,2	30	72	€ 81,08	

- > Zaagblad voor exotisch hout, spaanplaat, MDFplaten tot 50mm, met een goed resultaat. Dit item is een verbeterd type LU06M EC3, waarbij het hardmetaal H00S is vervangen door H00X. Geluidsarme uitvoering.
- > Sawblade for cutting exotic and abrasive woods, chipboard, MDF panels up to 50 mm with a good finish. Use on table saws. This item is an upgrading of the sawblade LU06M EC3 where the HM was changed from H00S to H00X and the low noise system added.

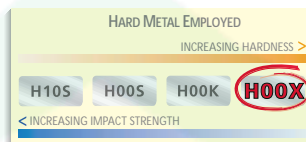
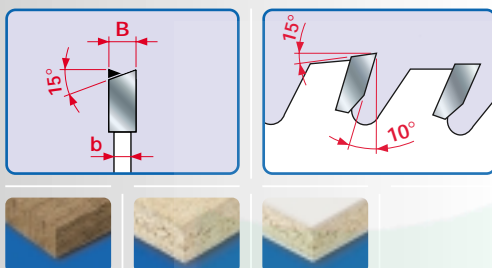

# LU26M

## HM FORMAATZAAGBLAD TRAPEZIUM VLAKTAND

### T.C.T. SAWBLADES FOR CUTTING LAMINATED PANELS

STANDAARD  
STANDARD

GELUIDSARM  
LOW NOISE

permaSHIELD



ART.	D mm	B/b mm	d mm	Z	LU26 M	LU26M SS	LU26M T
LU26M FB3	250	3,2 / 2,2	30	60	€ 70,24		
LU26M HB3	300	3,2 / 2,2	30	72	€ 75,40		

- > Op formaat zagen van tweezijdig bekleed spaanplaat en meubelplaat. perfecte afwerking bij gebruik op machines met voorritszaag. Tevens voor eenzijdig bekleed MDF-materiaal op machines zonder voorrits met goed resultaat.
- > Sawblade for cutting, in combination with scorer, with excellent finish, on coated chipboard, plywood, veneer with max. kerf 40 mm. Without scorer, good finish on chipboard and MDF coated on one side only. Use on table saw.

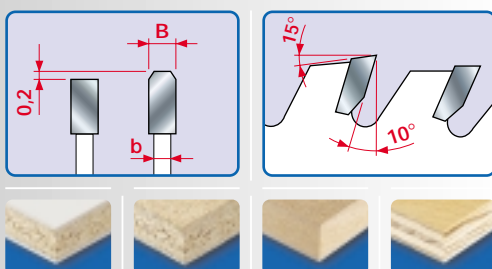

# LU11M

## HM FORMAATZAAGBLAD TRAPEZIUM VLAKTAND T.C.T. SAWBLADES FOR CUTTING LAMINATED PANELS

STANDAARD STANDARD GELUIDSARM LOW NOISE permaSHIELD

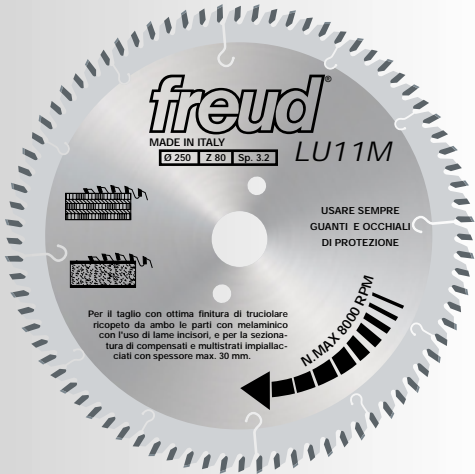

ART.	D mm	B/b mm	d mm	Z	LU11 M	LU11M SS	LU11M T
LU11M CB3	200	3,2 / 2,2	30	64	€ 63,52		
LU11M DB3	250	3,2 / 2,2	30	80	€ 70,38	€ 84,84	€ 77,61
LU11M EC3	300	3,2 / 2,2	30	96	€ 86,98	€ 98,34	€ 95,76
LU11M EE3	300	3,2 / 2,5	35	96	€ 86,98		
LU11M FC3	350	3,5 / 2,5	30	108	€ 113,10	€ 130,15	€ 124,47

> Op formaat zagen van tweezijdig bekleed spaanplaat en meubelplaat. perfecte afwerking bij gebruik op machines met voorritszaag. Tevens voor eenzijdig bekleed MDF-materiaal op machines zonder voorrits met goed resultaat.

> Sawblade for cutting, in combination with scorer, with excellent finish, on coated chipboard, plywood, veneer with max. kerf 30 mm. Without scorer, good finish on chipboard and MDF coated on one side only. Use on table saw.

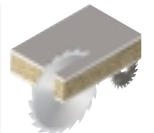
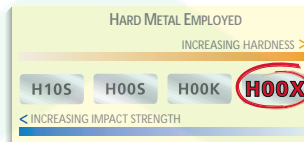
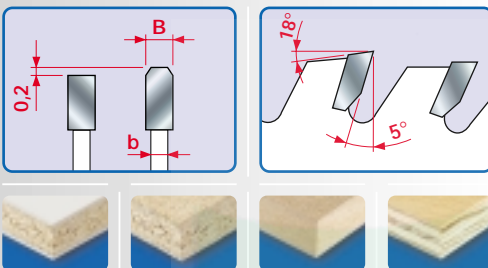

# LU27M

## HM ZAAGBLAD MET PERMASHIELD BEKLEED TRAPEZIUM VLAKTAND T.C.T. SAWBLADES FOR CUTTING LAMINATED PANELS

STANDAARD STANDARD GELUIDSARM LOW NOISE permaSHIELD

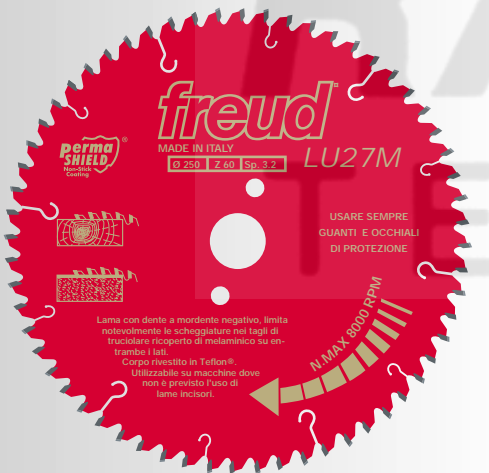

ART.	D mm	B/b mm	d mm	Z	LU27 M	LU27M SS
LU27M DB3	220	3,2 / 2,2	30	56	€ 63,01	
LU27M FB3	250	3,2 / 2,2	30	60	€ 65,73	
LU27M HB3	300	3,2 / 2,2	30	72	€ 82,33	
LU27M KB3	350	3,5 / 2,5	30	84	€ 106,91	

> Zaagblad bekleed met permaSHIELD voor het formaatzagen van tweezijdig bekleed spaanplaatmateriaal. Negatieve tandvorm. te gebruiken op tafelzaagmachine en verticale platenzaagmachine aanbevolen voor machines zonder voorritser.

> Sawblade for cutting double faced laminated chipboard without chipping. Specially designed with a negative cutting angle and tips made of a special grade of carbide. It is ideal for table saws not fitted with scorer or for wall saws. permaSHIELD coating to reduce heat build up due to friction.

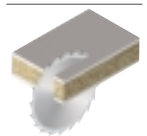
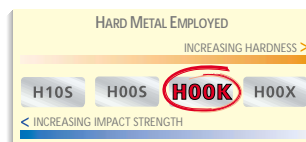
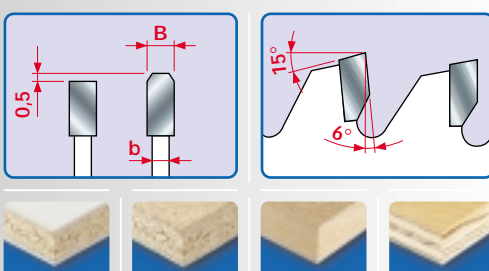



# LU12MSS

HM UNIVERSEEL ZAAGBLAD WISSELTAND

T.C.T. SAWBLADES FOR CUTTING LAMINATED PANELS

STANDAARD  
STANDARD

GELUIDSARM  
LOW NOISE

permaSHIELD

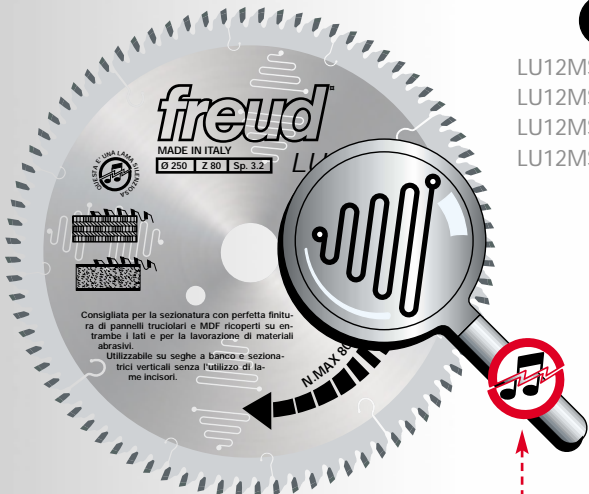

ART.	D mm	B/b mm	d mm	Z	LU12 M	LU12M SS	LU12M T
LU12MSS DB3	220	3,2 / 2,2	30	64		€ 75,92	
LU12MSS FB3	250	3,2 / 2,2	30	80		€ 83,81	
LU12MSS HB3	300	3,2 / 2,2	30	96		€ 106,09	
LU12MSS HB3	350	3,2 / 2,5	30	108		€ 134,28	

ART.	NL aantal meeneemgaten/nr pin holes	d diam. meeneemgaten/pin hole's diameter	TK PCD
LU12MSS DB3	2	6 mm	42 mm
LU12MSS FB3 / KB3	2	10 / 7 mm	60 mm
LU12MSS HB3	2	6 mm	42 mm
	2	10 mm	60 mm

- > Zaagblad voor het zagen van dubbelzijdig gelamineerd (spaan-) materiaal met variabele snijhoek (zie tabel). Geen voorritszaak nodig, met speciale bewerking voor drastische geluidsvermindering.
- > Sawblade for cutting double sided laminated panels with an excellent finish without the need of a scoring blade. With the perfect hook angle for each diameter ( $\alpha$ ) and with high alternate bevel to avoid splintering. The revolutionary laser cuts filled with a particular material drastically reduce the noise level and the vibration. Use on table or wall saw.

Maximaal geluid demping  
Maximum noise reduction



Geen ritszaak nodig  
Scorer no required



Cod.	$\alpha$	$\beta$	$\gamma$
LU12MSS DB3	- 5°	25°	38°
LU12MSS FB3	- 2°	25°	38°
LU12MSS HB3	+ 2°	25°	38°
LU12MSS KB3	+ 5°	25°	38°

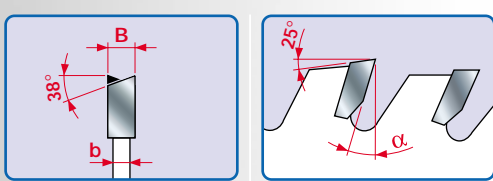

HARD METAL EMPLOYED  
INCREASING HARDNESS >

H10S H00S **HOOK** H00X

< INCREASING IMPACT STRENGTH

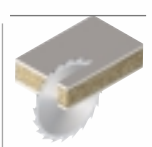

# LU13MSS

## HM ZAAGBLAD MET HOLLE TANDVORM

### T.C.T. SAWBLADES FOR CUTTING LAMINATED PANELS

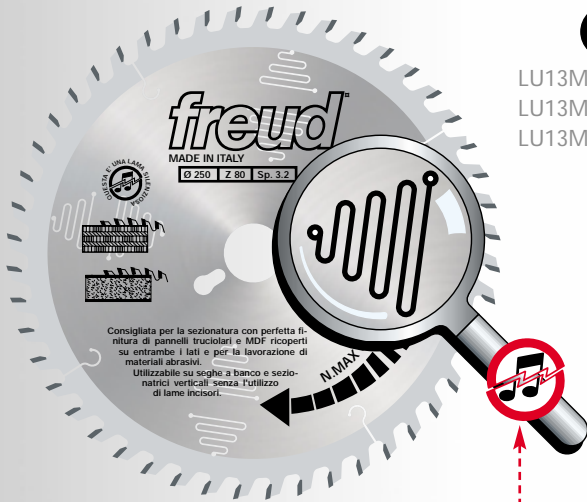

STANDAARD STANDARD GELUIDSARM LOW NOISE permaSHIELD

ART.	D mm	B/b mm	d mm	Z	LU13 M	LU13M SS	LU13M T
LU13MSS DB3	220	3,2 / 2,2	30	42		€ 69,72	
LU13MSS FB3	250	3,2 / 2,2	30	48		€ 74,27	
LU13MSS HB3	303	3,2 / 2,2	30	60		€ 89,16	

ART.	NL aantal meeneemgaten/nr. pin holes	d diam. meeneemgaten/pin holes diameter	TK PCD
LU13MSS DB3	2	6 mm	42 mm
LU13MSS FB3 / HB3	2	10 / 7 mm	42/60 mm

- > Zaagblad met holle tandvorm voor het zagen van dubbelzijdig gelamineerde panelen, zonder gebruik van een voorritszaag. Niet geschikt voor het zagen van gefineerd hout.
- > Sawblade with hollow ground tooth for cutting double sided laminated panels with an excellent finish without the need of a scoring blade. The revolutionary laser cuts filled with a particular material drastically reduce the noise level and the vibrations. Not recommended for plywood cutting. Using on table or wall saw.

Maximaal geluid demping  
Maximum noise reduction

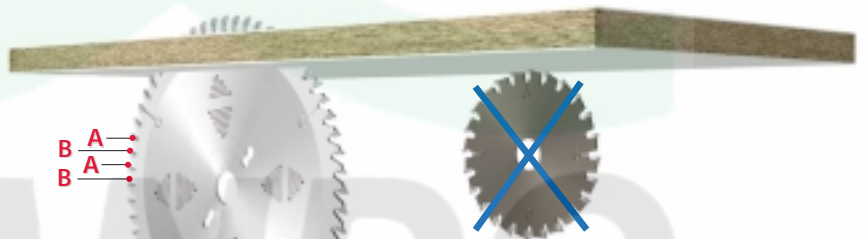

Geen ritszaag nodig  
Scorer no required

- > Functie van de holle tandvorm:

De tanden A en B (figuur 1 en 2) zijn afwisselend aangebracht. de bijzondere vorm van de tand bewerkstelligt een trekkende beweging en reduceert daarmee splintervorming. Tand A met zijn bijzondere dakvorm funktioneert als voorritser.

- > FEATURES:

The teeth "A" and "B" (Fig. 1 and 2) alternate on the blade. The hollow shape on the front of the tooth allows a progressive impact of the tooth against the material to be cut, starting from the sides and arriving at its centre. In this way a rough cut is made which helps to remove the material, thus avoiding the pressure on the panel which causes chips. The "A" type tooth, because of the sharp edge, allows a finishing cut.

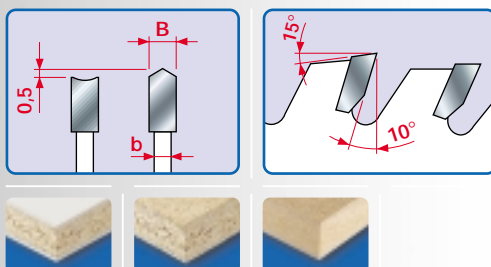
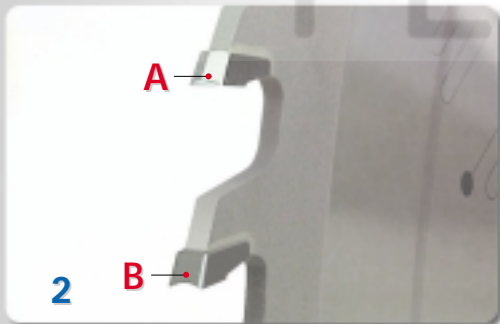
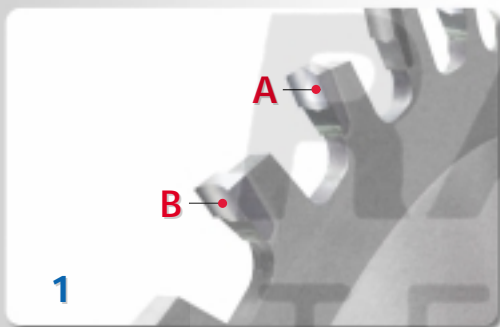

HARD METAL EMPLOYED

INCREASING HARDNESS >

H10S H00S H00K **H00X**

< INCREASING IMPACT STRENGTH

# LU28M

## HM SPECIAALZAAGBLAD MET PERMASHIELD BEKLEED WISSELTAND T.C.T. HYPER FINISH MITER SAWBLADES

STANDAARD  
STANDARD

GELUIDSARM  
LOW NOISE

permaSHIELD



ART.	D mm	B / b mm	d mm	Z	LU28 <b>M</b>	LU28M <b>SS</b>	
LU28M	CB3	200	2,95 / 2,5	30	64	€ 67,14	
LU28M	FA3	250	2,95 / 2,5	20	80	€ 79,68	
LU28M	FB3	250	2,95 / 2,5	30	80	€ 79,68	
LU28M	GA3	275	2,95 / 2,5	20	84	○	
LU28M	HB3	300	2,95 / 2,5	35	96	€ 98,34	
LU28M	IB3	330	3,45 / 3,0	30	96	€ 121,88	
LU28M	KB3	350	3,45 / 3,0	30	108	€ 124,47	

- > Speciaal zaagblad voor verstekzagen en afkorten van massief houten lijsten, ook voor delikaat en broos (gips-) materiaal, geeft een perfecte afwerking. Speciaal voor lijsten.
- > Special sawblade for an excellent and clean cross cut of wooden picture frames coated with delicate and abrasive materials. Gives a perfect finish without splintering even cross cutting at 45°. A permaSHIELD coating is applied to the blade body to act as a "lubricant". Use on automatic or manual miter saw.

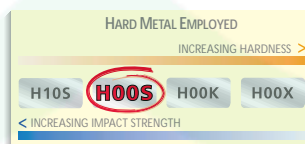
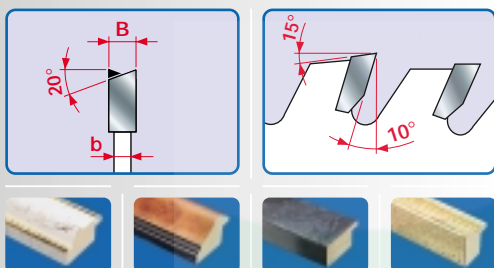

# LU30M

## HM ZAAGBLAD VOOR KUNSTSTOF TRAPEZIUM VLAKTAND T.C.T. SAWBLADES FOR CUTTING PLASTIC

STANDAARD  
STANDARD

GELUIDSARM  
LOW NOISE

permaSHIELD



ART.	D mm	B / b mm	d mm	Z	LU30 <b>M</b>	LU30M <b>SS</b>	LU30M <b>T</b>
LU30M	FB3	250	2,8 / 2,2	30	80	€ 83,29	
LU30M	HB3	300	2,8 / 2,2	30	96	€ 92,14	

- > Zaagblad met negatieve tandvorm voor het zagen van kunststofmateriaal en acrylglas zonder versmelting van het te bewerken materiaal. Belangrijk: de tand moet ca 30mm boven het materiaal uitsteken.
- > Sawblade for cutting plastic materials and plexiglas. This blade is designed with a negative hook angle and tips made of a special grade of carbide, giving a perfect finish without melting or scratching the material. For a correct application, the blade must work 30 mm above the material cut.

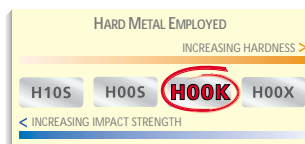
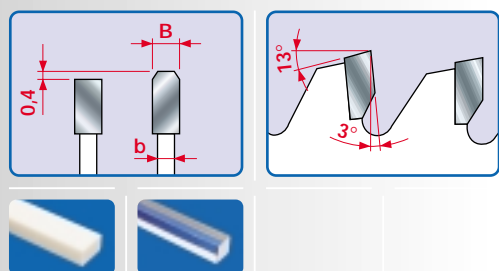

freud

○ VRAAG NAAR BESCHIKBAARHEID  
ASK FOR AVAILABILITY

# LU20M

## HM ZAAGBLAD VOOR NON-FERROUS MATERIAAL TRAPEZIUM VLAKTAND T.C.T. SAWBLADES FOR CUTTING NON-FERROUS METALS

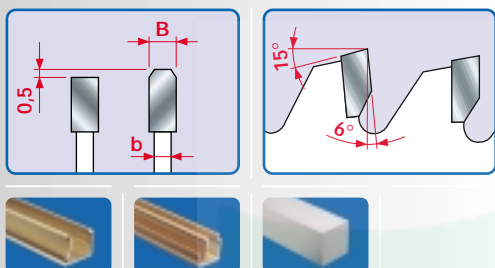

STANDAARD STANDARD GELUIDSARM LOW NOISE permaSHIELD

ART.	D mm	B/b mm	d mm	Z	LU20 M	LU20M SS	LU20M T
LU20M FB3	250	3,5 / 3,0	30	80	€ 79,16		
LU20M FC3	250	3,5 / 3,0	32	80	€ 79,16		
LU20M HB3	300	3,5 / 3,0	30	96	€ 100,41		
LU20M HC3	300	3,5 / 3,0	32	96	€ 100,41		
LU20M IB3	330	3,5 / 3,0	30	104	€ 115,69		
LU20M KB3	350	3,5 / 3,0	30	108	€ 118,27		
LU20M KC3	350	3,5 / 3,0	32	108	€ 118,27		

ART.	NL aantal meeneemgaten/nr pin holes	d diam. meeneemgaten/pin hole's diameter	TK PCD
All LU20M's	2	11 mm	63 mm

> Zaagblad met negatieve tand voor het zagen van aluminium en andere non-ferrous materialen tot een dikte van 3 mm. Geschikt voor handdoorvoer.

> Sawblade with a negative hook angle for cutting aluminium and other non-ferrous profiles with wall thickness up to 3 mm. Suitable for machines without automatic clamping.

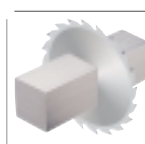
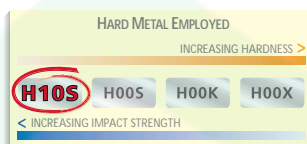

# LU21M

## HM ZAAGBLAD VOOR NON-FERROUS MATERIAAL TRAPEZIUM VLAKTAND T.C.T. SAWBLADES FOR CUTTING NON-FERROUS METALS

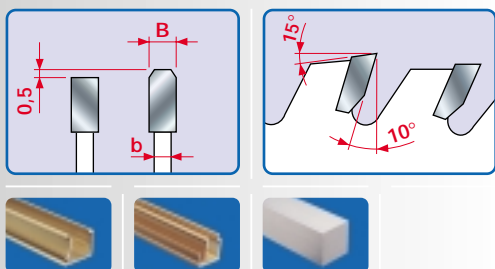

STANDAARD STANDARD GELUIDSARM LOW NOISE permaSHIELD

ART.	D mm	B/b mm	d mm	Z	LU21 M	LU21M SS	LU21M T
LU21M AA3	250	3,5 / 3,0	32	60	€ 70,90		
LU21M BA3	300	3,5 / 3,0	32	72	€ 88,53		
LU21M CA3	350	3,5 / 3,0	32	84	€ 106,91		
LU21M DA3	400	3,5 / 3,0	32	96	€ 125,50		
LU21M EA3	450	4,0 / 3,2	32	108	€ 195,22		
LU21M FB3	500	4,0 / 3,2	32	120	€ 198,32		

ART.	NL aantal meeneemgaten/nr pin holes	d diam. meeneemgaten/pin hole's diameter	TK PCD
All LU21M's	2	11 mm	63 mm

> Zaagblad met positieve tand voor het zagen van aluminium en andere non-ferrous materialen tot een dikte van 10 mm.

ATTENTIE: alleen geschikt voor automatische doorvoer.

> Sawblade for cutting aluminium and other non-ferrous profiles with wall thickness up to 10 mm.

ATTENTION: The work piece must be properly clamped during cutting.

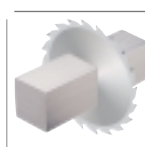
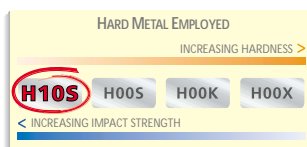

# LU22M

## HM ZAAGBLAD VOOR NON-FERROUS MATERIAAL TRAPEZIUM VLAKTAND T.C.T. SAWBLADES FOR CUTTING NON-FERROUS METALS

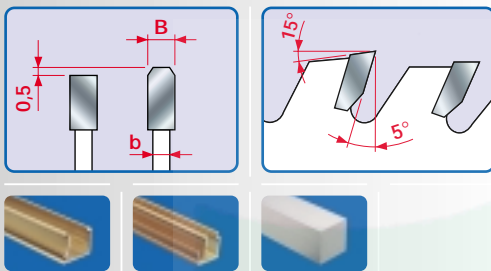

ART.	D mm	B / b mm	d mm	Z	STANDAARD	GELUIDSARM	permaSHIELD
					STANDARD	LOW NOISE	
					LU22 M	LU22M SS	LU22M T
LU22M	AA3	250	3,5 / 3,0	32	80	€ 84,32	
LU22M	BA3	300	3,5 / 3,0	32	96	€ 101,95	
LU22M	CA3	350	3,5 / 3,0	32	108	€ 117,75	
LU22M	DA3	400	3,5 / 3,0	32	120	€ 139,44	
LU22M	EA3	450	4,0 / 3,5	32	128	€ 225,18	
LU22M	FA3	500	4,0 / 3,0	32	140	€ 227,24	

ART.	NL aantal meeneemgaten/nr pin holes	d diam. meeneemgaten/pin hole's diameter	TK PCD
All LU22M's	2	11 mm	63 mm

- > Te gebruiken als de LU20M, maar met positieve tand voor automatische doorvoer.
  - > Sawblade for cutting aluminium and other non-ferrous profiles with wall thickness up to 3 mm.
- ATTENTION: The work piece must be properly clamped during cutting.

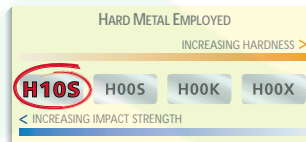

# LU38M

## HM ZAAGBLAD VOOR NON-FERROUS MATERIAAL TRAPEZIUM VLAKTAND T.C.T. SAWBLADES FOR CUTTING NON-FERROUS METALS

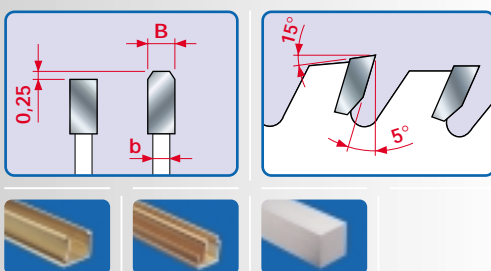
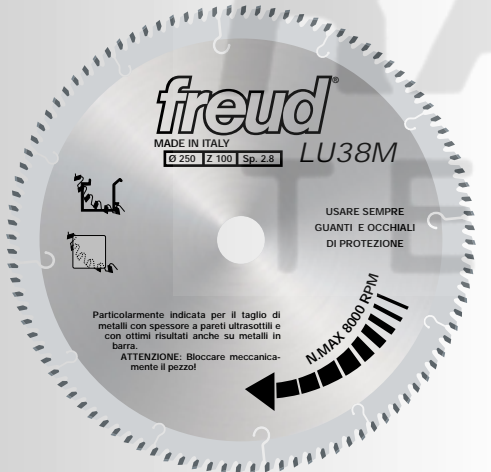

ART.	D mm	B / b mm	d mm	Z	STANDAARD	GELUIDSARM	permaSHIELD
					STANDARD	LOW NOISE	
					LU38 M	LU38M SS	LU38M T
LU38M	FR3	250	2,8 / 2,2	25,4	100	€ 75,54	
LU38M	FC3	250	2,8 / 2,2	32	100	€ 75,54	
LU38M	QB3	350	3,0 / 2,5	30	120	€ 94,00	
LU38M	RB3	350	3,0 / 2,5	30	100	€ 84,70	

- > Te gebruiken als de LU21M, voor zeer dunne materialen. Te gebruiken bij automatische doorvoer.
  - > Sawblade for cutting aluminium and other non-ferrous profiles with very thin wall thickness. Excellent for also cutting plain aluminium or non-ferrous bars.
- ATTENTION: the work piece must be properly clamped during cutting.

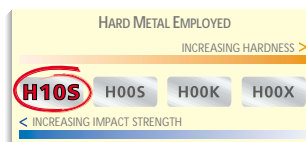

# permaSHIELD bekleed zaagblad

## permaSHIELD coated blades

**permaSHIELD**  
Non-Stick Coating



permaSHIELD® is een unieke coating met eigenschappen die een algehele bescherming geeft tegen roest, lijm- en harsvorming.

permaSHIELD® is a unique synthetic coating with non stick characteristics that give all round protection against rust, glue and resin build up.



permaSHIELD® coating beschermt het zaagblad tegen roest.

permaSHIELD® coating preserves the blade against rust.



permaSHIELD® coating vermindert de hitte toename gedurende het arbeidsproces.

permaSHIELD® coating reduces heat build up during the working process.

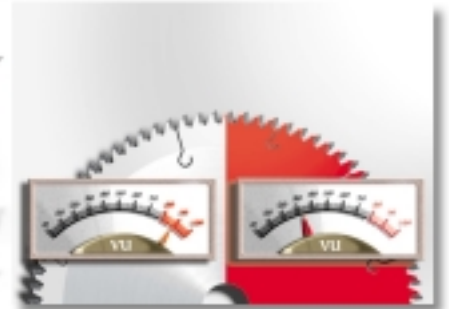

permaSHIELD® coating kan een energie-besparing opleveren tot 55%.

permaSHIELD® coating allows you to reduce energy costs up to 55%.



# LM46M

## HM MEERBLADZAAG WISSELTAND T.C.T. RIPPING SAWBLADES

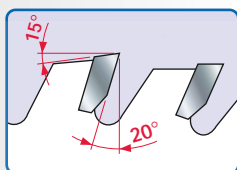
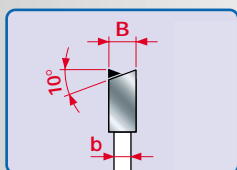

ART.	D mm	B/b mm	d mm	Z	STANDAARD	GELUIDSARM
					STANDARD	LOW NOISE
					LM46 M	LM46M SS
LM46M DA3	250	3,2 / 2,2	30	24	€ 46,27	
LM46M DD3	250	3,2 / 2,2	70	24	€ 46,27	
LM46M FA3	300	3,2 / 2,2	30	28	€ 58,23	
LM46M FC3	300	3,2 / 2,2	60	28	€ 58,23	
LM46M FD3	300	3,2 / 2,2	70	28	€ 58,23	
LM46M HA3	350	3,5 / 2,5	30	32	€ 75,40	€ 85,73
LM46M HD3	350	3,5 / 2,5	70	32	€ 75,40	

ASGAT • BORE	mm	60	70		
SPIEBAAN • KEYWAY	mm	21x5	21x5		

> permaSHIELD bekleed zaagblad voor het schulpen van zacht, hard en exotische houtsoorten zonder knoesten. Dit zaagblad kan ook worden gebruikt om af te korten.

Te gebruiken op meerbladzaagmachines of tafelzaagmachines.

> permaSHIELD coated sawblade for ripping dry softwoods, hardwoods and exotic woods, up to 60 mm thick without loose knots.

This sawblade can also be used for crosscutting.

Use on multirip machines or table saw.

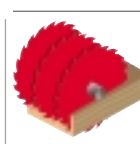

# LM58M

## HM MEERBLADZAAG WISSELTAND T.C.T. HIGH-TECH RIPPING SAWBLADES

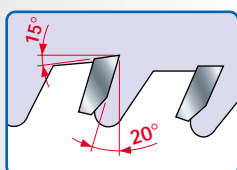
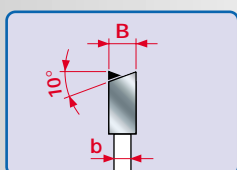
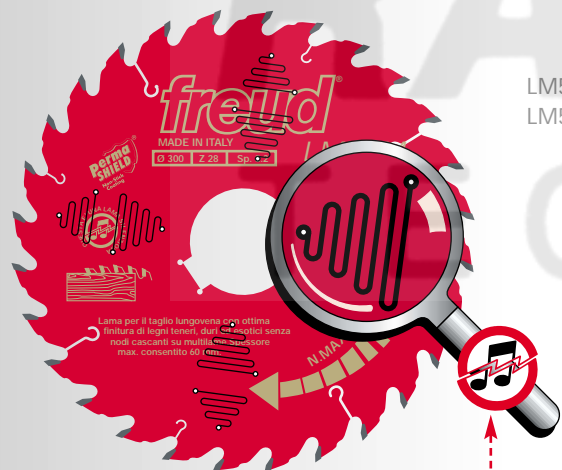

ART.	D mm	B/b mm	d mm	Z	STANDAARD	GELUIDSARM
					STANDARD	LOW NOISE
					LM58 M	LM58M SS
LM58M FA3	300	3,2 / 2,2	30	28	€ 67,01	
LM58M FD3	300	3,2 / 2,2	70	28	€ 67,01	

  

ASGAT • BORE	mm	70			
SPIEBAAN • KEYWAY	mm	21x5			

> permaSHIELD bekleed geluidsarm zaagblad voor het schulpen zachte, harde en exotische houtsoorten zonder knoesten, tot 60 mm. Te gebruiken op tafelzaagmachine en meerbladzaagmachine.

> permaSHIELD coated sawblade with low noise design. Sawblade for ripping pre-finished dry softwoods, hardwoods and exotic woods up to 60 mm thick without loose knots. Long life sawblade with excellent results. Use on multirip machines.

### Maximaal geluid demping Maximum noise reduction

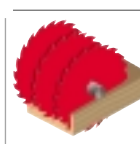

# LM47M

## HM SCHULPZAAGBLAD WISSELTAND MET SPAANBEGRENZER T.C.T. RIPPING SAWBLADES WITH ANTI-KICK BACK DESIGN

STANDAARD  
STANDARD

GELUIDSARM  
LOW NOISE



ART.	D mm	B / b mm	d mm	Z	LM47 <b>M</b>	LM47M <b>SS</b>
------	---------	-------------	---------	---	---------------	-----------------

LM47M	DA3	250	3,2 / 2,2	30	22	€ 48,34	
LM47M	DD3	250	3,2 / 2,2	70	22	€ 48,34	
LM47M	FA3	300	3,2 / 2,2	30	26	€ 55,13	
LM47M	FB3	300	3,2 / 2,2	35	26	€ 55,13	
LM47M	FD3	300	3,2 / 2,2	70	26	€ 55,13	
LM47M	HA3	350	3,5 / 2,5	30	30	€ 73,85	€ 96,06
LM47M	HB3	350	3,5 / 2,5	35	30	€ 73,85	€ 96,06
LM47M	HD3	350	3,5 / 2,5	70	30	€ 73,85	
LM47M	KA3	400	4,0 / 2,8	30	34	€ 95,54	

ASGAT • BORE	mm	70		
SPIEBAAN • KEYWAY	mm	21x5		

- > permaSHIELD bekleed zaagblad voor het schulpen van droog hard- en zacht hout, ook met knoesten, tot 60mm.
- > permaSHIELD coated ATB sawblade for ripping dry softwoods and hardwoods up to 60 mm thick with loose knots. Use on multirip machines and bench saws.

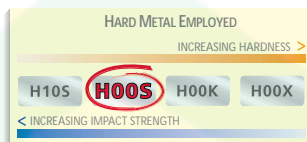
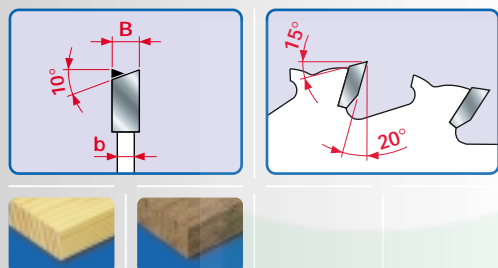

# LM59M

## HM MEERBLADZAAG WISSELTAND MET SPAANBEGRENZER T.C.T. RIPPING SAWBLADES WITH ANTI-KICK BACK DESIGN

STANDAARD  
STANDARD

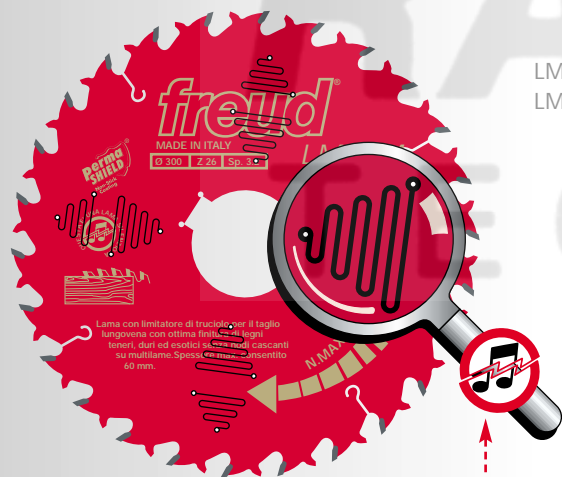

ART.	D mm	B / b mm	d mm	Z	LM59 <b>M</b>
------	---------	-------------	---------	---	---------------

LM59M	FA3	300	3,2 / 2,2	30	26	€ 64,95
LM59M	FD3	300	3,2 / 2,2	70	26	€ 64,95

ASGAT • BORE	mm	70		
SPIEBAAN • KEYWAY	mm	21x5		

- > permaSHIELD bekleed geluidsarm zaagblad voor langszagen van droog zacht - en hardhout, ook met knoesten, tot 60mm.
- > permaSHIELD coated sawblade with low noise design. ATB sawblade for ripping pre-finished dry softwoods and hardwoods up to 60 mm thick with loose knots. Long life sawblade with excellent results. Use on multirip machines.

Maximaal geluid demping  
Maximum noise reduction

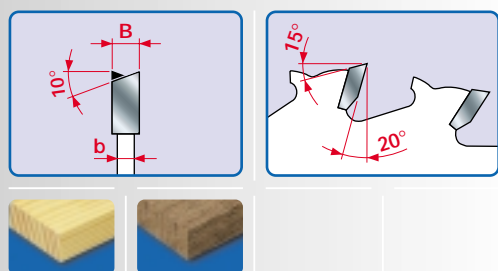



# LM42M

## HM MEERBLADZAAG VLAKTAND MET SPAANBEGRENZER T.C.T. RIPPING SAWBLADES WITH ANTI-KICK BACK DESIGN



STANDAARD STANDARD GELUIDSARM LOW NOISE

ART.	D mm	B/b mm	d mm	Z	LM42 M	LM42M SS
LM42M FL3	300	2,6 / 1,8	25	24	€ 47,39	
LM42M HL3	350	3,0 / 2,2	25	28	€ 67,14	

- > permaSHIELD beklede bouwzaag voor schulpen en afkorten van vochtig zacht- en hardhout, ook met knoesten of spijkers, tot 60 mm.
- > permaSHIELD coated sawblade for ripping low quality, dry or wet hardwoods and softwoods with loose knots or nails. Suitable for site joiners, this sawblade gives acceptable finish on manual feed table saws. Max depth of cut is 60 mm.

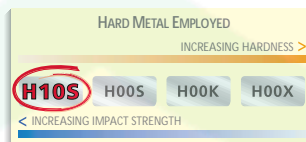
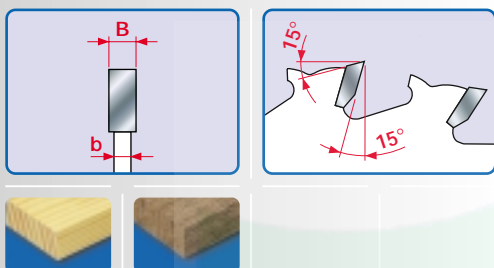

# LM50M

## HM MEERBLADZAAG VLAKTAND MET SPAANBEGRENZER EN WISSERS T.C.T. RIPPING SAWBLADES WITH ANTI-KICK BACK DESIGN AND RAKERS



STANDAARD STANDARD GELUIDSARM LOW NOISE

ART.	D mm	B/b mm	d mm	Z	LM50 M	LM50M SS
LM50M AB3	180	2,2 / 1,6	40	16+2	€ 42,35	
LM50M BB3	200	2,2 / 1,6	40	16+2	€ 45,45	
LM50M BC3	200	2,2 / 1,6	60	16+2	€ 45,45	
LM50M DC3	250	2,2 / 1,6	60	20+2	€ 53,50	
LM50M DD3	250	2,2 / 1,6	70	20+2	€ 53,50	
LM50M DE3	250	2,2 / 1,6	80	20+2	€ 53,50	
LM50M FC3	300	2,5 / 1,8	60	24+2	€ 68,05	
LM50M FD3	300	2,5 / 1,8	70	24+2	€ 68,05	
LM50M FE3	350	2,5 / 1,8	80	24+2	€ 68,05	

ASGAT • BORE	mm	40	60	70	80
SPIEBAAN • KEYWAY	mm	12x4	21x5	21x5	12,5x4
DIAMETER • SAWBLADE DIAMETER	mm	180	200	250	300
MAXIMALE ZAAGDIEPTE • MAX DEPTH OF CUT	mm	30 ↓	35 ↓	40 ↓	50

- > permaSHIELD bekleed zaagblad met een zeer goede snijkwaliteit bij natuurochtige en droge houtsoorten, niet geschikt voor krom materiaal; weinig materiaalverlies door geringe snijdikte.
- > permaSHIELD coated sawblade for ripping all types of dry or wet woods with good finish. Thin kerf makes this blade suitable for cutting quality materials reducing waste. NOT RECOMMENDED FOR CUTTING CROOKED PLANKS. The blade can also be used on moulding machines for dividing planks with excellent finish (Ø 180 and Ø 200 mm).

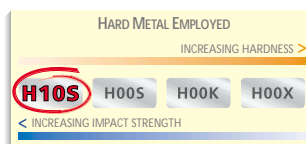
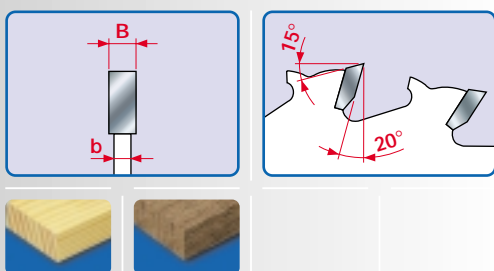

freud

# LM51M

## HM MEERBLADZAAG VLAKTAND MET SPAANBEGRENZER EN WISSERS T.C.T. RIPPING SAWBLADES WITH ANTI-KICK BACK DESIGN AND RAKERS

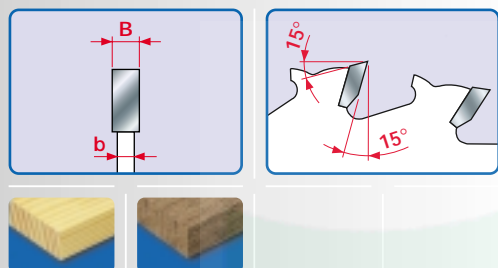
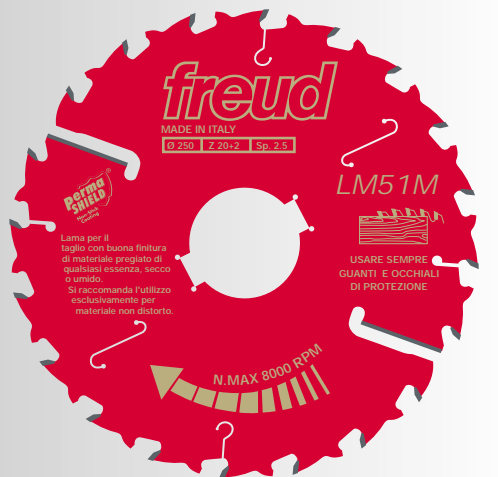

ART.	D mm	B / b mm	d mm	Z	STANDAARD	GELUIDSARM
					STANDARD	LOW NOISE
					LM51 M	LM51M SS
LM51M DD3	250	2,5 / 1,8	70	20+2	€ 55,05	
LM51M DE3	250	2,5 / 1,8	70	20+2	€ 55,05	
ASGAT • BORE				mm	70	80
SPIEBAAN • KEYWAY				mm	21x5	12,5x4
DIAMETER • SAWBLADE DIAMETER				mm	250	
MAXIMALE ZAAGDIEPTE • MAX DEPTH OF CUT				mm	40 ↓	

- > Te gebruik als LM50M. Door dikker stamblad ook geschikt voor hardere materialen.
- > Sawblade for ripping all types of dry and wet woods with good finish. Thin kerf makes this blade suitable for cutting quality materials, reducing waste. Use on multirip machines.

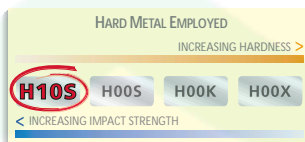

# LM54M

## HM MEERBLADZAAG VLAKTAND MET SPAANBEGRENZER EN WISSERS T.C.T. RIPPING SAWBLADES WITH ANTI-KICK BACK DESIGN AND RAKERS

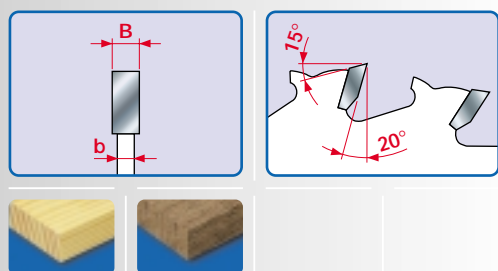

ART.	D mm	B / b mm	d mm	Z	STANDAARD	GELUIDSARM		
					STANDARD	LOW NOISE		
					LM54 M	LM54M SS		
LM54M FA3	300	3,2 / 2,2	30	20+2	€ 69,60			
LM54M FC3	300	3,2 / 2,2	60	20+2	€ 69,60			
LM54M FD3	300	3,2 / 2,2	70	20+2	€ 69,60			
LM54M FE3	300	3,2 / 2,2	80	20+2	€ 69,60			
LM54M GE3	320	3,2 / 2,2	80	20+4	€ 96,58			
LM54M HA3	350	3,5 / 2,5	30	24+4	€ 98,13			
LM54M HD3	350	3,5 / 2,5	70	24+4	€ 98,13			
LM54M KA3*	400	4,0 / 2,8	30	28+6	€ 137,38			
LM54M KD3*	450	4,0 / 2,8	70	28+6	€ 137,38			
ASGAT • BORE				mm	30	60	70	80
SPIEBAAN • KEYWAY				mm	12x4	21x5	21x5	12,5x4
DIAMETER • SAWBLADE DIAMETER				mm	300	320	350	400
MAXIMALE ZAAGDIEPTE • MAX DEPTH OF CUT				mm	60 ↓	70 ↓	80 ↓	100

- > permaSHIELD bekleed zaagblad voor schulpen bij alle houtsoorten, droog, nat of krom met gemiddelde sijkwaliteit. Te gebruiken op machines met mechanische aanvoer. Bijzonder geschikt voor de pallet industrie.

\*D=400 zonder spaanbegrenzers

- > permaSHIELD coated sawblade for ripping all types of dry, wet, crooked palnks with low grade finish. Recommended for manufacturing pallets and cutting poplar. Use on multirip machines or table saw with automatic feed.

\*Items LM54M KA3 and LM54M KD3 are not designed with anti-kick back.



# LM63M

## HM MEERBLADZAAG MET WISSERS T.C.T. RIPPING SAWBLADES WITH RAKERS

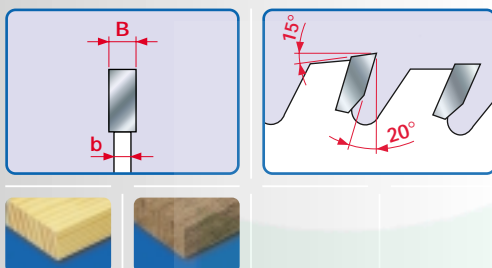

STANDAARD STANDARD GELUIDSARM LOW NOISE

ART.	D mm	B/b mm	d mm	Z	LM63 M	LM63M SS
LM63M CD3	225	2,5 / 1,8	70	16+4	€ 67,66	
LM63M DD3	250	2,8 / 2,0	70	16+4	€ 72,61	
LM63M DE3	250	2,8 / 2,0	80	16+4	€ 72,61	
LM63M EE3	280	2,8 / 2,0	80	18+4	€ 80,57	
LM63M FC3	300	2,8 / 2,0	60	20+4	€ 81,99	
LM63M FD3	300	2,8 / 2,0	70	20+4	€ 81,99	
LM63M FE3	300	2,8 / 2,0	80	20+4	€ 81,99	
LM63M HA3	350	3,0 / 2,2	30	24+6	€ 108,46	
LM63M HD3	350	3,0 / 2,2	70	24+6	€ 108,46	

ASGAT • BORE	mm	30	60	70	80	
SPIEBAAN • KEYWAY	mm	10x4	21x5	21x5	12,5x4	
DIAMETER • SAWBLADE DIAMETER	mm	225	250	280	300	350
MAXIMALE ZAAGDIEPTE • MAX DEPTH OF CUT	mm	45 ↓	50 ↓	60 ↓	70	100

- > permaSHIELD bekleed zaagblad, geschikt voor alle houtsoorten, behalve populierenhout, met gemiddelde snijkwaliteit. Te gebruiken op meerbladzaagmachine.
- > permaSHIELD coated sawblade for ripping all types of straight planks, wet or moderately dry with medium finish. Not recommended for cutting poplar. Use on multirip machines.

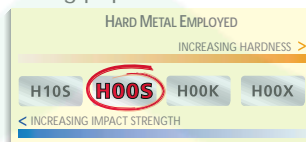

# LM64M

## HM MEERBLADZAAG MET WISSERS T.C.T. HIGH-TECH RIPPING SAWBLADES WITH RAKERS

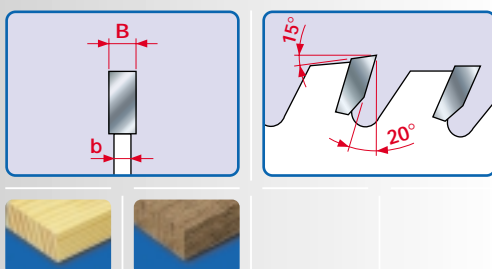

STANDAARD STANDARD GELUIDSARM LOW NOISE

ART.	D mm	B/b mm	d mm	Z	LM64 M	LM64M SS
LM64M DA3	250	3,2 / 2,2	30	16+4	€ 71,58	
LM64M DC3	250	3,2 / 2,2	60	16+4	€ 71,58	
LM64M DD3	250	3,2 / 2,2	70	16+4	€ 71,58	
LM64M DE3	250	3,2 / 2,2	80	16+4	€ 71,58	
LM64M FA3	300	3,2 / 2,2	30	20+4	€ 77,86	
LM64M FC3	300	3,2 / 2,2	60	20+4	€ 77,86	
LM64M FD3	300	3,2 / 2,2	70	20+4	€ 77,86	
LM64M FE3	300	3,2 / 2,2	80	20+4	€ 77,86	
LM64M HA3	350	3,5 / 2,5	30	24+6	€ 111,04	
LM64M HC3	350	3,5 / 2,5	60	24+6	€ 111,04	
LM64M HD3	350	3,5 / 2,5	70	24+6	€ 111,04	
LM64M HE3	350	3,5 / 2,5	80	24+6	€ 111,04	

ASGAT • BORE	mm	30	60	70	80
SPIEBAAN • KEYWAY	mm	10x4	21x5	21x5	12,5x4
DIAMETER • SAWBLADE DIAMETER	mm	250	300	350	
MAXIMALE ZAAGDIEPTE • MAX DEPTH OF CUT	mm	50 ↓	70 ↓	100 ↓	

- > permaSHIELD bekleed zaagblad, geschikt voor alle houtsoorten, behalve populierenhout, met gemiddelde snijkwaliteit. Te gebruiken op meerbladzaagmachine.
- > permaSHIELD coated sawblade for ripping all types of straight planks, wet or moderately dry with medium finish. Not recommended for cutting poplar. Use on multirip machines.



# LM65M

## HM MEERBLADZAAG VLAKTAND MET WISSERS T.C.T. RIPPING SAWBLADES WITH RAKERS

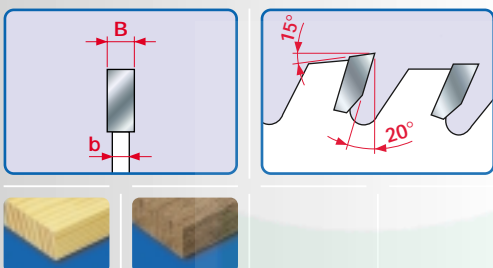

ART.	D mm	B/b mm	d mm	Z	STANDAARD STANDARD	GELUIDSARM LOW NOISE
					LM65 <b>M</b>	LM65M <b>SS</b>
LM65M	DD3	250	3,2 / 2,2	70	20+4	€ 72,10
LM65M	DE3	250	3,2 / 2,2	80	20+4	€ 72,10
LM65M	FC3	300	3,2 / 2,2	60	24+4	€ 78,89
LM65M	FD3	300	3,2 / 2,2	70	24+4	€ 78,89
LM65M	FE3	300	3,2 / 2,2	80	24+4	€ 78,89
LM65M	HD3	350	3,5 / 2,5	70	28+6	€ 112,07
LM65M	HE3	350	3,5 / 2,5	80	28+6	€ 112,07

ASGAT • BORE	mm	60	70	80	
SPIEBAAN • KEYWAY	mm	21x5	21x5	12,5x4	
DIAMETER • SAWBLADE DIAMETER	mm	250	300	350	
MAXIMALE ZAAGDIEPTE • MAX DEPTH OF CUT	mm	50 ↓	70 ↓	100 ↓	

- > permaSHIELD zaagblad voor het zagen van alle soorten vochtig of droog hout voor pallets of kisten met goede snijkwaliteit.
- > permaSHIELD coated sawblade for ripping all types of wet or dry, crooked planks with good finish. Recommended for heavy duty use, especially in saw mills and for cutting poplar. Excellent for cutting short workpieces at high feed rates.



# LM66M

## HM MEERBLADZAAG VLAKTAND MET WISSERS T.C.T. HIGH-TECH RIPPING SAWBLADES WITH RAKERS

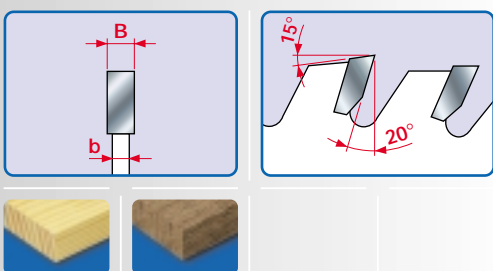

ART.	D mm	B/b mm	d mm	Z	STANDAARD STANDARD	GELUIDSARM LOW NOISE
					LM66 <b>M</b>	LM66M <b>SS</b>
LM66M	FD3	300	3,2 / 2,2	70	24+4	€ 91,29
LM66M	FE3	300	3,2 / 2,2	80	24+4	€ 91,29
LM66M	HD3	350	3,5 / 2,5	70	28+6	€ 123,95

ASGAT • BORE	mm	70	80	
SPIEBAAN • KEYWAY	mm	21x5	12,5x4	
DIAMETER • SAWBLADE DIAMETER	mm	300	350	
MAXIMALE ZAAGDIEPTE • MAX DEPTH OF CUT	mm	70 ↓	100 ↓	

- > permaSHIELD zaagblad, geluidsarm, voor het zagen van alle houtsoorten, met een goede snij-kwaliteit. Geschikt voor pallet-en emballage industrie.
- > permaSHIELD coated sawblade with low noise design. Sawblade for ripping crooked planks, wet or dry, with excellent finish. Long life sawblade with excellent results. Recommended for heavy duty use, especially in saw mills and for manufacturing pallets. Also for cutting poplar.

**Maximaal geluid demping  
Maximum noise reduction**



# LS46M

## HM OPDEELZAAGBLAD WISSELTAND T.C.T. PANEL SIZING SAWBLADES

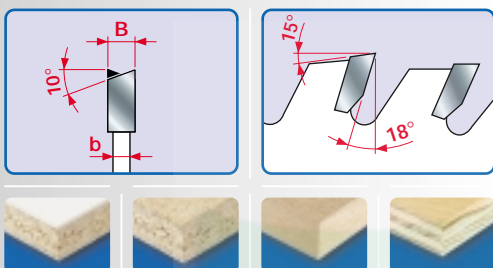

STANDAARD STANDARD GELUIDSARM LOW NOISE permaSHIELD

ART.	D mm	B/b mm	d mm	Z	LS46 M	LS46M SS	LS46M T
LS46M AA3	350	4,6 / 3,0	30	54	€ 114,14		
LS46M AB3	350	4,6 / 3,0	75	54	€ 114,14		
LS46M BA3	400	4,6 / 3,0	30	60	€ 129,11		
LS46M BB3	400	4,6 / 3,0	75	60	€ 129,11		
LS46M BC3	400	4,6 / 3,0	80	60	€ 129,11		

ART.	NL aantal meeneemgaten/nr. pin holes	d diam. meeneemgaten/pin hole's diameter	TK PCD
LS46M AA3	2	10 mm	60 mm
LS46M AA3/BC3	4	9 mm	100 mm
	2	9 mm	110 mm

- > Zaagblad voor het opdelen en formaatzagen van spaanplaten en multiplex platen tot een zaaghoogte van 80/100 mm.
- > Sawblade for sizing with good finish on multiple chipboard and hard fiber panels up to 80/100 mm.

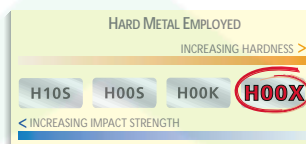

# LS47M

## HM OPDEELZAAGBLAD TRAPEZIUM VLAKTAND T.C.T. PANEL SIZING SAWBLADES

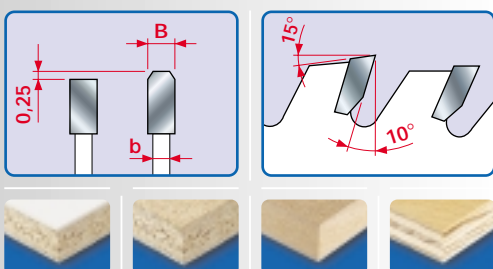

STANDAARD STANDARD GELUIDSARM LOW NOISE permaSHIELD

ART.	D mm	B/b mm	d mm	Z	LS47 M	LS47M SS	LS47M T
LS47M AA3	350	4,6 / 3,0	30	56	€ 113,62	€ 135,31	
LS47M AB3	350	4,6 / 3,0	75	56	€ 113,62		
LS47M AC3	350	4,6 / 3,0	80	56	€ 113,62	€ 135,31	
LS47M BA3	400	4,6 / 3,0	30	60	€ 132,21		
LS47M BB3	400	4,6 / 3,0	75	60	€ 132,21		
LS47M BC3	400	4,6 / 3,0	80	60	€ 132,21		
LS47M HB3	420	4,6 / 3,0	75	60	€ 190,57		

ART.	NL aantal meeneemgaten/nr. pin holes	d diam. meeneemgaten/pin hole's diameter	TK PCD
LS47M AA3/BC3	2	9 mm	110 mm

- > Zaagblad voor geplastificeerd spaanplaat tot 100mm zaaghoogte.
- > Sawblade for sizing with good finish on multiple chipboard panels coated with melamine or laminates up to 100 mm.

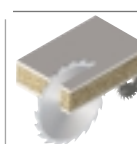
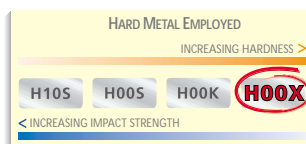

# LS48M

## HM OPDEELZAAG TRAPEZIUM VLAKTAND T.C.T. PANEL SIZING SAWBLADES

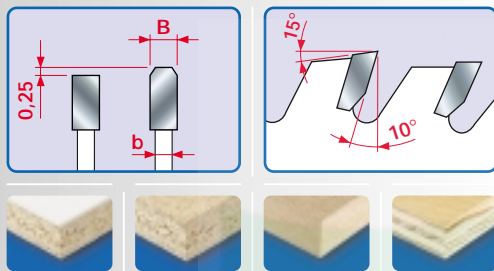
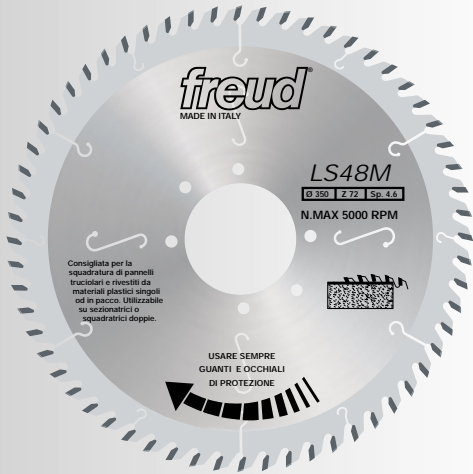

ART.	D mm	B / b mm	d mm	Z	STANDAARD STANDARD	GELUIDSARM LOW NOISE	permaSHIELD
					LS48 [M]	LS48M [SS]	LS48M [T]
LS48M FA3	300	4,6 / 3,0	30	60	€ 103,17	€ 123,31	
LS48M AA3	350	4,6 / 3,0	30	72	€ 128,60	€ 152,87	
LS48M AB3	350	4,6 / 3,0	75	72	€ 128,60	€ 152,87	
LS48M AC3	350	4,6 / 3,0	80	72	€ 128,60	€ 152,87	

ART.	NL aantal meeneemgaten/nr. pin holes	d diam. meeneemgaten/pin hole's diameter	TK PCD
LS48M AC3	4	9 mm	100 mm
	2	9 mm	110 mm

- > Zaagblad voor geplastificeerd spaanplaat tot 60mm met zeer goede snijkwaliteit.
- > Sawblade for sizing with excellent finish on single and multiple chipboard panels coated with melamine or laminates up to 60 mm. Use on panel sizing machines, professional table saws, double end tenoning machines.

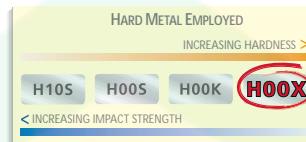

# LS49M

## HM OPDEELZAAG WISSELTAND T.C.T. PANEL SIZING SAWBLADES

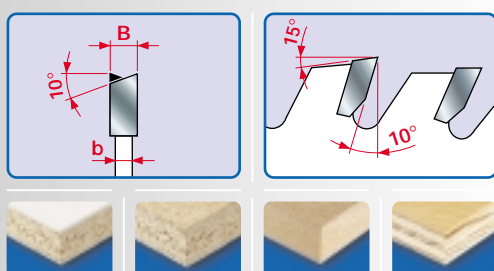

ART.	D mm	B / b mm	d mm	Z	STANDAARD STANDARD	GELUIDSARM LOW NOISE	permaSHIELD
					LS49 [M]	LS49M [SS]	LS49M [T]
LS49M AA3	350	3,5 / 2,5	30	54	€ 100,19		
LS49M AB3	350	3,5 / 2,5	75	54	€ 100,19		

- > Zaagblad voor alle plaatmaterialen en multiplexplaten tot 80mm snijhoogte. Voor SCM machine: d=30mm: voorritszaag: LI25M34KC3.
- > Sawblade for sizing with good finish on thick, multiple chipboard panels. Also recommended for sizing hard fiber panels and compressed woods. Maximum stack thickness 80 mm. Use on SCM machine (d= 30 mm) along with Freud's LI25M34KC3 scorer.

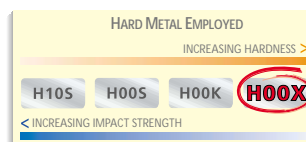

# LS50M

## HM OPDEELZAAG T.C.T. PANEL SIZING SAWBLADES



STANDAARD STANDARD    GELUIDSARM LOW NOISE    permaSHIELD

ART.	D mm	B / b mm	d mm	Z	LS50 M	LS50M SS	LS50M T
LS50M EC3	500	4,6 / 3,2	80	60	€ 213,30		
LS50M FC3	550	4,6 / 3,2	80	60	€ 266,49		
LS50M FF3	550	4,6 / 3,2	100	60	€ 266,49		

ART.	NL aantal meeneemgaten/nr pin holes	d diam. meeneemgaten/pin hole's diameter	TK PCD
All LS50M's	4	9 mm	100 mm
	2	9 mm	110 mm

- > Zaagblad voor spaanplaat, ook in pakket, ook geschikt voor hardboard en multiplex tot 110 mm snijhoogte.
- > Sawblade for sizing with good finish on single and multiple chipboard panels up to 110 mm. Recommended for cutting hard fiber panels and compressed woods.

### > LS50M EC3

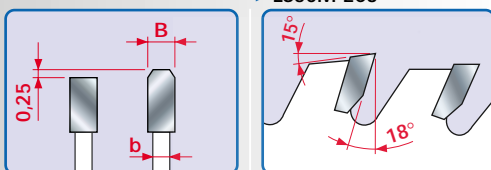

### > LS50M FC3 - LS50M FF3

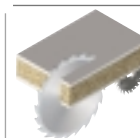
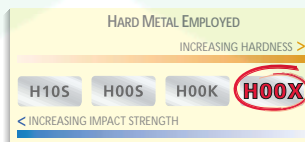
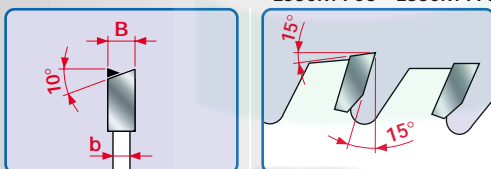

# LI22MD LI22MS

RECHTS  
RIGHT  
LINKS  
LEFT

## HM VOORRITZAAG MET SCHUINE VERTANDING T.C.T. BEVELLED TOOTH SCORING SAWBLADES

STANDAARD STANDARD    GELUIDSARM LOW NOISE    permaSHIELD



ART.	D mm	B / b mm	d mm	Z	LI22 M	LI22M SS	LI22M T
LI22MD/S KC3	150	3,2 / 2,2	30	36	€ 45,45		
LI22MD/S KG3	150	3,2 / 2,2	55	36	€ 45,45		
LI22MD/S KH3	150	3,2 / 2,2	60	36	€ 45,45		
LI22MD/S NC3	180	3,2 / 2,2	30	42	€ 58,88		
LI22MD/S NG3	180	3,2 / 2,2	55	42	€ 58,88		

- > Voorritser met linkse of rechtse vertanding voor het voorritsen in parallelloop met de hoofdzaag.
- > Scoring sawblades with left or right bevel teeth for cutting panels coated with laminates or thermohardened resins on both sides  
Rotation with the feed.

Links • Left | Rechts • Right

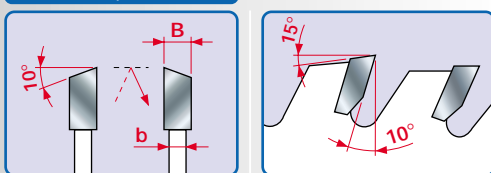

Verspaner

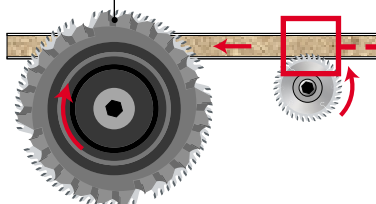

Snijbreedte van de hoofdzaag  
Cutting kerf of main sawblade

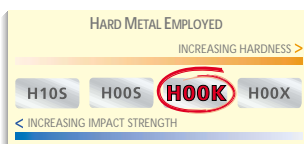
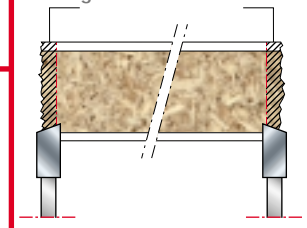

freud

# LI16M

## HM VOORRITSZAAG VERSTELBAAR VLAKTAND-TWEEDELIG T.C.T. ADJUSTABLE SCORING SAWBLADE



STANDAARD STANDARD GELUIDSARM LOW NOISE permaSHIELD

ART.	D mm	B mm	d mm	Z	LI16 M	LI16M SS	LI16M T
LI16M BA3	100	2,8-3,6	20	12+12	€ 73,34		
LI16M BB3	100	2,8-3,6	22	12+12	€ 73,34		
LI16M CA3	105	2,8-3,6	20	10+10	€ 67,14		
LI16M AA3	120	2,8-3,6	20	12+12	€ 73,34		
LI16M AB3	120	2,8-3,6	22	12+12	€ 73,34		
LI16M FA3	125	2,8-3,6	20	12+12	€ 73,34		
LI16M EA3	125	2,8-3,6	20	14+14	€ 80,05		
LI16M EB3	125	2,8-3,6	22	14+14	€ 80,05		
LI16M DA3	125	4,0-4,7	20	20+20	€ 98,13		

- > Voorritser in parallelloop met de hoofdzaag, maximale voorritsdiepte 2mm.
- > Scoring sawblade to be used together with panel sizing blade to avoid chipping on lower side of panels coated on both sides. Scoring depth up to 2 mm. Use on machines that do not allow adjustment of scoring depth.

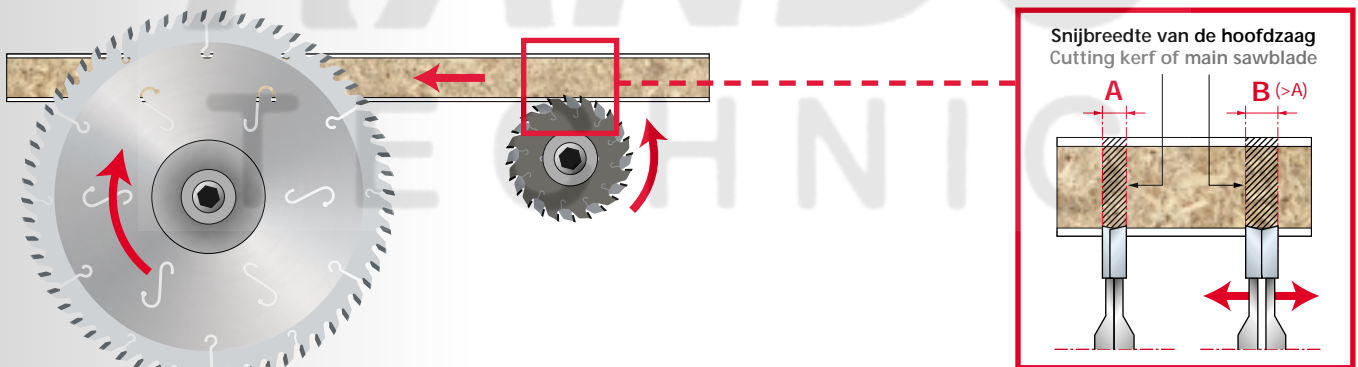
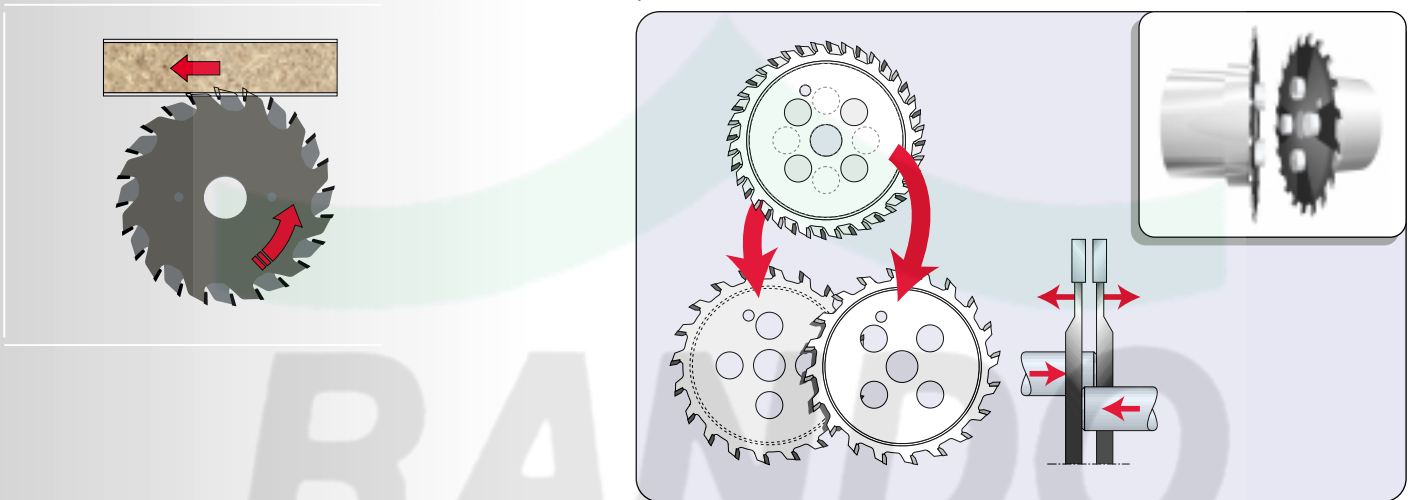

ART.	NL aantal meeneemgaten/nr. pin holes	d diam. meeneemgaten/pin hole's diameter	TK PCD
LI16M DA3	afstelgaten 4 + 4 positie gaten 1	17 mm 7 mm	50 mm

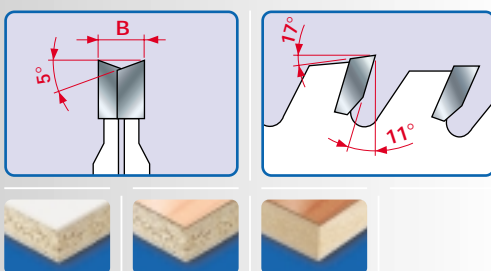



# LI25M

## HM VOORRITZAAG MET KONISCHE TANDVORM T.C.T. CONICAL SCORING SAWBLADE

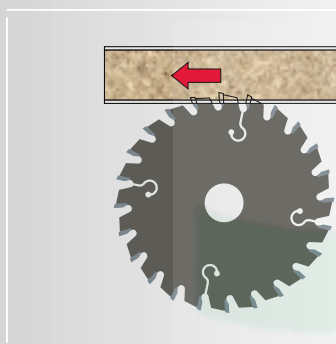

STANDAARD STANDARD GELUIDSARM LOW NOISE permaSHIELD

ART.	D mm	B - B1 / b mm	d mm	Z	LI25 M	LI25M SS	LI25M T
LI25M 28EA3	120	2,8-4,0 / 2,2	20	24	€ 31,50		
LI25M 28EB3	120	2,8-4,0 / 2,2	22	24	€ 31,50		
LI25M 31BA3	100	3,1-4,3 / 2,2	20	24	€ 38,22		
LI25M 31BB3	100	3,1-4,3 / 2,2	22	24	€ 40,00		
LI25M 31DA3	115	3,1-4,3 / 2,2	20	24	€ 38,22		
LI25M 31EA3	120	3,1-4,3 / 2,2	20	24	€ 36,15		
LI25M 31EB3	120	3,1-4,3 / 2,2	22	24	€ 36,15		
LI25M 31FA3	125	3,1-4,3 / 2,2	20	24	€ 37,70		
LI25M 31FB3	125	3,1-4,3 / 2,2	22	24	€ 37,70		
LI25M 34EA3	120	3,4-4,6 / 2,2	20	24	€ 37,70		
LI25M 34FA3	125	3,4-4,6 / 2,2	20	24	€ 36,67		
LI25M 34FE3	125	3,4-4,6 / 2,2	45	24	€ 36,67		
LI25M 34KC3	150	3,4-4,6 / 2,2	30	36	€ 48,55		
LI25M 43FA3	125	4,3-5,5 / 3,0	20	24	€ 41,83		
LI25M 43FE3	125	4,3-5,5 / 3,0	45	24	€ 41,83		
LI25M 43KC3	150	4,3-5,5 / 3,0	30	36	€ 53,20		
LI25M 45FA3	125	4,5-5,7 / 3,0	20	24	€ 39,77		
LI25M 45FE3	125	4,5-5,7 / 3,0	45	24	€ 39,77		
LI25M 45KC3	150	4,5-5,7 / 3,0	30	36	€ 51,13		
LI25M 45KE3	150	4,5-5,7 / 3,0	45	36	€ 51,13		
LI25M 45LE3	160	4,5-5,7 / 3,0	45	36	○		
LI25M 45LG3	160	4,5-5,7 / 3,0	55	36	€ 55,78		
LI25M 45NA3	180	4,5-5,7 / 3,0	20	36	€ 67,14		
LI25M 45PB3	200	4,5-5,7 / 3,0	22	36	€ 62,49		
LI25M 45PI3	200	4,5-5,7 / 3,0	65	36	€ 62,49		
LI25M 45PF3	215	4,5-5,7 / 3,2	50	42	€ 92,96		

> Voorritser in parallelloop met de hoofdzaag, maximale voorritsdiepte 2mm.

> Same application as LI16M but for use on machines that allow the adjustment of the scoring blade in relation to the panel sizing sawblade kerf.

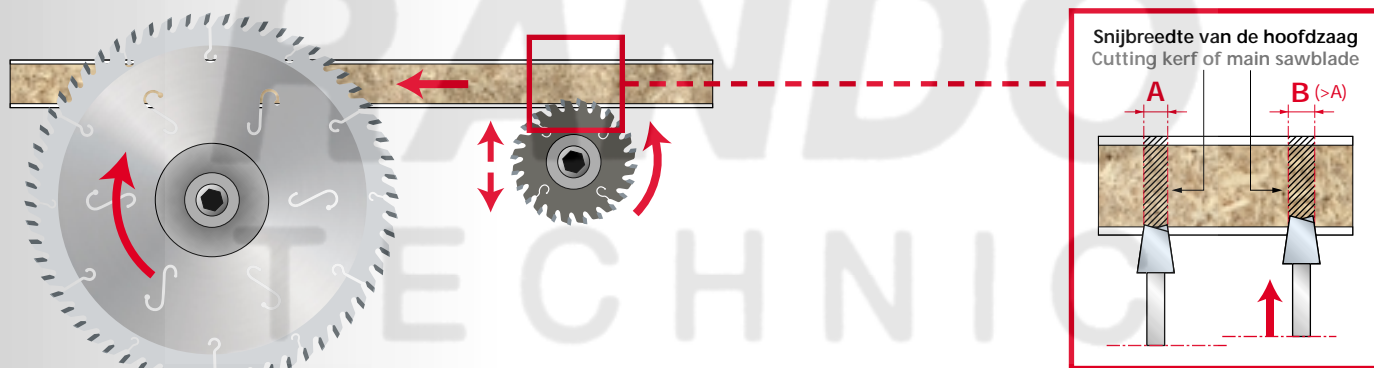

LI25M	α	LI25M	α
28EA3	0°	34EA3	0°
28EB3	0°	34FA3	0°
31DA3	0°	34FE3	0°
31EA3	0°	43FA3	0°
31FA3	0°	43FE3	0°
31EB3	0°	45FA3	0°
31FB3	0°	45FE3	0°

LI25M	α	LI25M	α
34KC3	8°	45PB3	8°
43KC3	8°	45PI3	8°
45KC3	8°	45PF3	8°
45KE3	8°		
45LE3	8°		
45LG3	8°		
45NA3	8°		

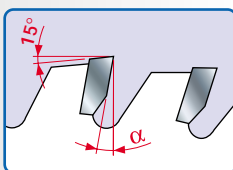
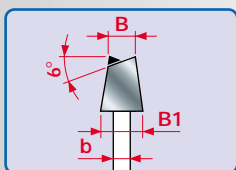

ART.	NL aantal meeneemgaten/nr/pin holes	d diam. meeneemgaten/pin hole's diameter	TK PCD
LI25M45 LG3	3	7 mm	66 mm
LI25M45 PF3	3	9 mm	72 mm
LI25M45 PI3	3	15 mm	80 mm
	2	8,5 mm	110 mm

B - B1 RITSBREEDETE • SCORER	B HOOFDZAAG • MAIN SAWBLADE
2,8 - 4,0 mm	2,9 mm
3,1 - 4,2 mm	3,2 mm
3,4 - 4,6 mm	3,5 mm
4,3 - 5,5 mm	4,4 mm
4,5 - 5,7 mm	4,6 mm

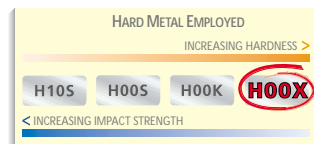

○ VRAAG NAAR BESCHIKBAARHEID  
ASK FOR AVAILABILITY

# INDUSTRIELE ZAAGBLADEN HANDCIRKELZAAGMACHINES

## THIN KERF PROFESSIONAL SAWBLADES FOR PORTABLE MACHINES

### Gele lijn Yellow line

**freud**  
pro

> Laag aantal tanden: voor schulpen en zachthout met goede snijkwaliteit. kies hiervoor de gele lijn!

> These blades are designed with a low number of teeth and are particularly fit for long grain cutting solid wood. These blades give a good finish if used in this way. If these are the blades you need, then choose the yellow line!

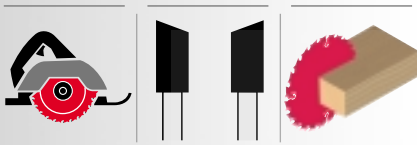

### Rode lijn Red line

**freud**  
pro

> Gemiddeld aantal tanden: voor schulpen en afkorten van hard- en zachthout met goede snijkwaliteit. kies hiervoor de rode lijn!

> These blades are designed with an average number of teeth and are particularly fit for both long grain and cross cutting solid wood. These blades give a good finish if used in this way. If these are the blades you need, choose the red line!

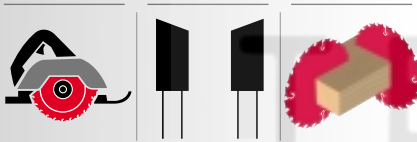

### Blauwe lijn Blue line

**freud**  
pro

> Hoog aantal tanden: voor schulpen en afkorten van hard- en zachthout met een zeer goed resultaat. kies hiervoor de blauwe lijn!

> These blades are designed with a high number of teeth and are particularly fit for cross grain cutting solid wood. These blades give a good finish if used in this way. If these are the blades you need, choose the blue line!

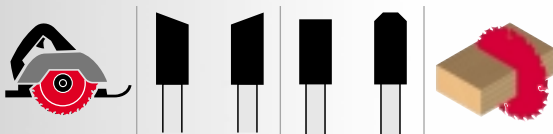

CODE mm	D mm	B/b mm	d	Z	Nr.	
LP20M 004	150	2,4 / 1,6	16	12	4	€ 19,11
LP20M 005	150	2,4 / 1,6	20	12	5	€ 19,11
LP20M 006	160	2,4 / 1,6	16	12	6	€ 19,63
LP20M 007	160	2,4 / 1,6	20	12	7	€ 19,63
LP20M 008	160	2,4 / 1,6	30	12	8	€ 19,63
LP20M 009	170	2,4 / 1,6	30	12	9	€ 19,63
LP20M 010	180	2,4 / 1,6	20	12	10	€ 19,63
LP20M 011	180	2,4 / 1,6	30	12	11	€ 19,63
LP20M 012	184	2,4 / 1,6	16	12	12	€ 20,40
LP20M 013	190	2,4 / 1,6	16	12	13	€ 21,17
LP20M 014	190	2,4 / 1,6	20	12	14	€ 21,17
LP20M 015	190	2,4 / 1,6	30	12	15	€ 21,17
LP20M 016	200	2,4 / 1,6	30	16	16	€ 23,24
LP20M 017	210	2,4 / 1,6	25	16	17	€ 25,05
LP20M 018	210	2,4 / 1,6	30	16	18	€ 25,05
LP20M 019	216	2,4 / 1,8	30	24	19	€ 31,76
LP20M 020	220	2,4 / 1,6	30	16	20	€ 26,34
LP20M 021	230	2,8 / 1,8	30	20	21	€ 29,70
LP20M 022	235	2,8 / 1,8	25	24	22	€ 32,02
LP20M 023	235	2,8 / 1,8	30	24	23	€ 32,02
LP20M 024	240	2,8 / 1,8	30	24	24	€ 32,28
LP20M 025	250	2,8 / 1,8	30	24	25	€ 33,57
LP30M 001	125	2,4 / 1,6	20	24	1	€ 25,31
LP30M 002	130	2,4 / 1,6	20	24	2	€ 25,31
LP30M 003	140	2,4 / 1,6	20	24	3	€ 25,31
LP30M 004	150	2,4 / 1,6	16	24	4	€ 25,82
LP30M 005	150	2,4 / 1,6	20	24	5	€ 25,82
LP30M 006	160	2,4 / 1,6	16	24	6	€ 25,82
LP30M 007	160	2,4 / 1,6	20	24	7	€ 25,82
LP30M 008	160	2,4 / 1,6	30	24	8	€ 25,82
LP30M 009	170	2,4 / 1,6	30	24	9	€ 26,08
LP30M 010	180	2,4 / 1,6	20	24	10	€ 26,08
LP30M 011	180	2,4 / 1,6	30	24	11	€ 26,08
LP30M 012	184	2,4 / 1,6	16	24	12	€ 26,60
LP30M 013	190	2,4 / 1,6	16	24	13	€ 27,37
LP30M 014	190	2,4 / 1,6	20	24	14	€ 27,37
LP30M 015	190	2,4 / 1,6	30	24	15	€ 27,37
LP30M 016	200	2,4 / 1,6	30	30	16	€ 30,73
LP30M 017	210	2,4 / 1,6	25	30	17	€ 32,54
LP30M 018	210	2,4 / 1,6	30	30	18	€ 32,54
LP30M 019	216	2,4 / 1,8	30	48	19	€ 45,19
LP30M 020	220	2,4 / 1,6	30	30	20	€ 33,57
LP30M 021	230	2,8 / 1,8	30	34	21	€ 37,44
LP30M 022	235	2,8 / 1,8	25	34	22	€ 37,44
LP30M 023	235	2,8 / 1,8	30	34	23	€ 37,44
LP30M 024	240	2,8 / 1,8	30	36	24	€ 38,73
LP30M 025	250	2,8 / 1,8	30	40	25	€ 42,35
LP40M 006	160	2,4 / 1,6	16	40	6	€ 34,34
LP40M 007	160	2,4 / 1,6	20	40	7	€ 34,34
LP40M 008	160	2,4 / 1,6	30	40	8	€ 34,34
LP40M 009	170	2,4 / 1,6	30	40	9	€ 34,86
LP40M 010	180	2,4 / 1,6	20	40	10	€ 34,86
LP40M 011	180	2,4 / 1,6	30	40	11	€ 34,86
LP40M 012	184	2,4 / 1,6	16	40	12	€ 35,12
LP40M 013	190	2,4 / 1,6	16	40	13	€ 35,64
LP40M 014	190	2,4 / 1,6	20	40	14	€ 35,64
LP40M 015	190	2,4 / 1,6	30	40	15	€ 35,64
LP40M 016	200	2,4 / 1,6	30	40	16	€ 35,89
LP40M 017	210	2,4 / 1,6	25	40	17	€ 38,22
LP40M 018	210	2,4 / 1,6	30	40	18	€ 38,22
LP40M 019	216	2,4 / 1,8	30	64	19	€ 54,23
LP40M 020	220	2,4 / 1,6	30	40	20	€ 38,73
LP40M 021	230	2,8 / 1,8	30	48	21	€ 44,93
LP40M 022	235	2,8 / 1,8	25	48	22	€ 44,93
LP40M 023	235	2,8 / 1,8	30	48	23	€ 44,93
LP40M 024	240	2,8 / 1,8	30	48	24	€ 44,93
LP40M 025	250	2,8 / 1,8	30	60	25	€ 52,68

# INDUSTRIELE ZAAGBLADEN HANDCIRKELZAAGMACHINES

## THIN KERF PROFESSIONAL SAWBLADES FOR PORTABLE MACHINES



CODE	D mm	B/b mm	d mm	Z	Toepassing Application	
LP60M 001	250	2,8 / 1,8	30	80	Hout/Wood	€ 67,14
LP60M 002	280	2,8 / 1,8	30	64	Hout/Wood	€ 65,07
LP60M 003	300	2,8 / 1,8	30	48	Hout/Wood	€ 56,81
LP60M 004	300	2,8 / 1,8	30	72	Hout/Wood	€ 72,30
LP60M 005	300	2,8 / 1,8	30	96	Hout/Wood	€ 82,63
LP60M 006	305	2,8 / 1,8	30	96	Hout/Wood	€ 87,80
LP60M 007	350	3,0 / 2,2	30	54	Hout/Wood	€ 71,79
LP60M 008	350	3,0 / 2,2	30	108	Hout/Wood	€ 101,23
LP70M 001	300	2,8 / 1,8	30	24	Bouwzaag On site jobs	€ 43,90
LP70M 002	350	3,0 / 2,2	30	28	Bouwzaag On site jobs	€ 56,81
LP70M 003	315	3,2 / 2,2	30	24	Bouwzaag On site jobs	€ 54,23
LP80M 001	250	2,8 / 2,2	30	80	NE - Alu/Alu	€ 80,05
LP80M 002	280	2,8 / 2,2	30	64	NE - Alu/Alu	€ 74,89
LP80M 003	300	2,8 / 2,2	30	96	NE - Alu/Alu	€ 98,13
LP80M 004	350	3,0 / 2,2	30	108	NE - Alu/Alu	€ 116,20
LP40M 019	216	2,4 / 1,8	30	64	NE - Alu/Alu	€ 54,23



- > Vervaardigd uit hoogwaardig staal in onze moderne fabrieken, staan deze zaagbladen garant voor een maximum aan kwaliteit en productiviteit.
- > Fitted on bench and radial saws, these blades are designed to assure top quality and performance based on the type of cutting operation. Professionals choose these blades for industrial applications.

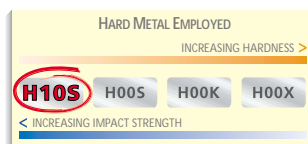
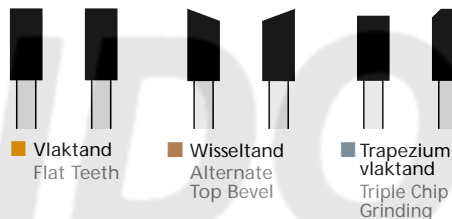



**freud**

AROUND THE WORLD



**GEREGISTREERD EIGENDOM:**

Deze catalogus is eigendom van Pozzo S.p.A. en mag niet worden gecopieerd, uitgegeven of gebruikt zonder schriftelijke toestemming.

**RESERVED OWNERSHIP RIGHTS:**

All rights are reserved in accordance with the law and with the international agreements. This catalogue may not be reproduced without prior authorisation in writing on the part of Pozzo S.p.A. Any modification of this catalogue will not be noticed in advance.