

Seghe radiali

Radial-arm saws / Scies radiales / Sierras radiales



HOUTBEWERKINGSMACHINES

AFZUIGINSTALLATIES

GEREEDSCHAPPEN



TEL. (0515) 43 15 70 - www.rando.nl - SNEEK

ONDERHOUD - REPARATIE - REVISIE

Junior 640 / Big 800

RANDO
TECHNIC



EC VERSION

since 1963



Best 960 / Best 1250

EC VERSION



Dettagli

Details / Détails / Detalles

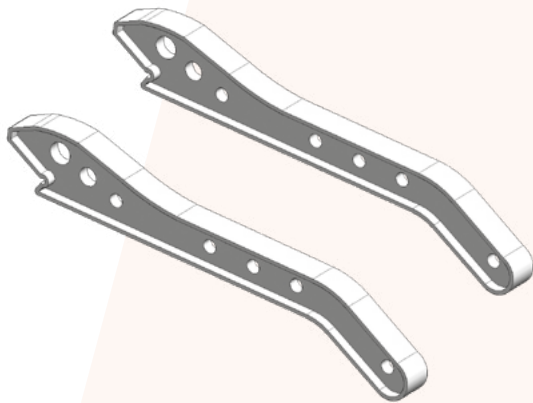

00005118 Spingilegno / Push-stick / Pousse-bois / Empujador

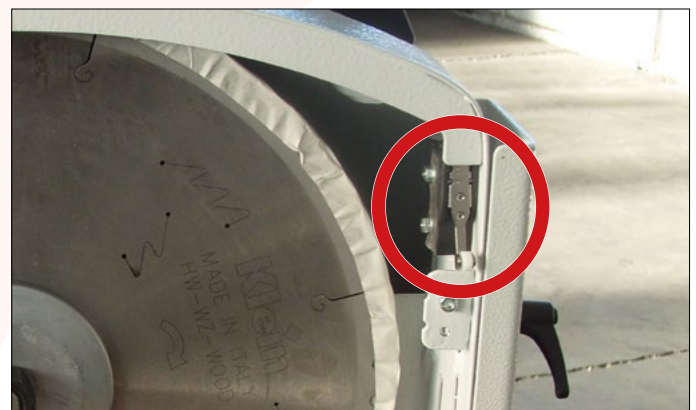

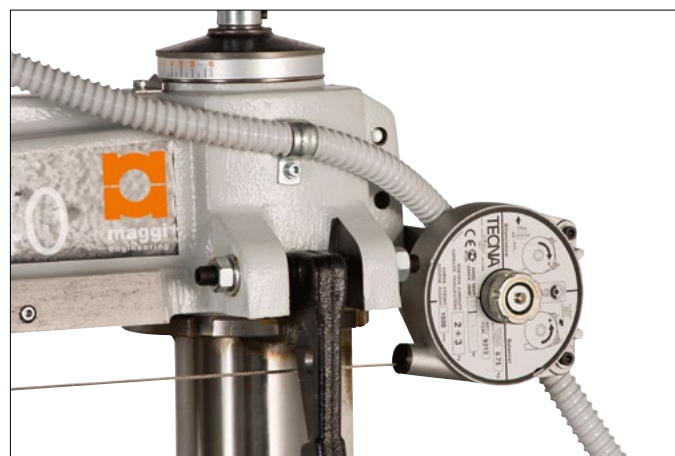
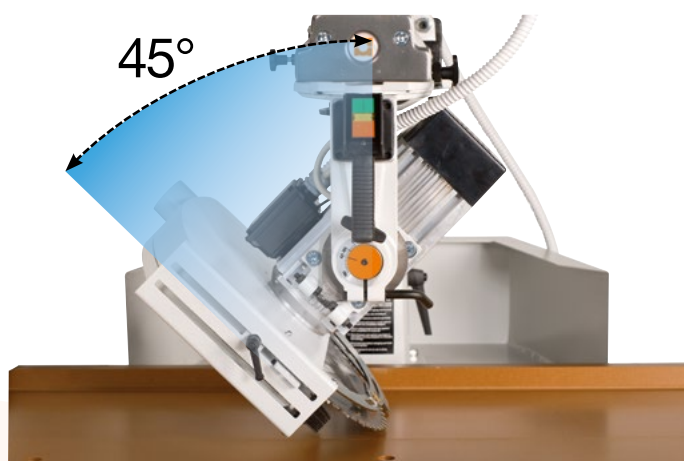

Accessori

Accessories / Optional / Accesorios



00015104 Ø 400 x 3,8 x 30 mm, Z=60

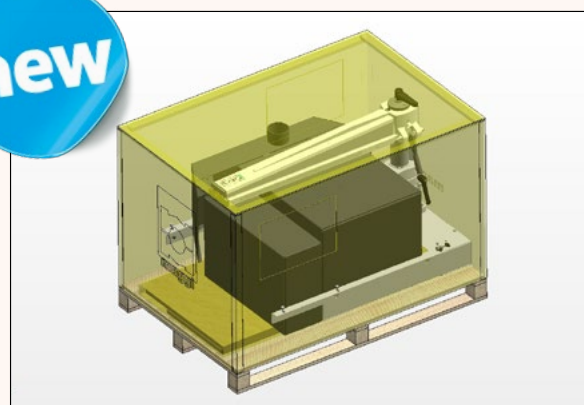

Best 960 / Best 1250



25416203 Laser

Best 700 S

Best 960 S / Best 1250 S



EC VERSION

since 1963



Dettagli

Details / Détails / Detalles

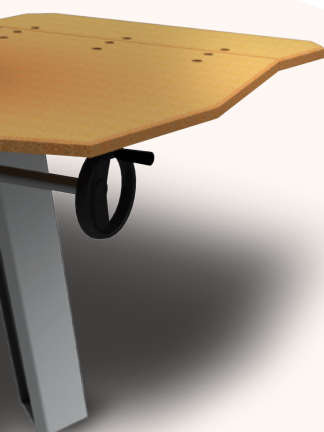
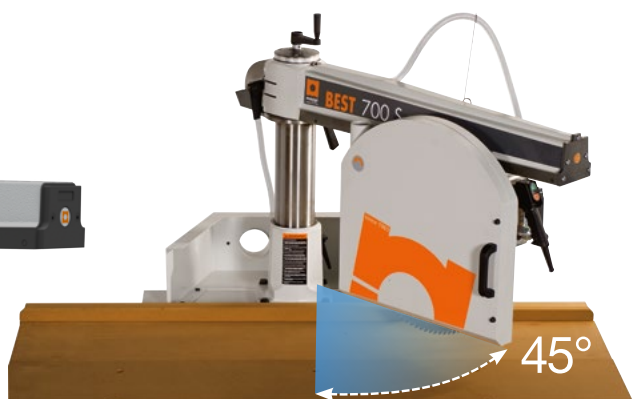

25404002 Best 700 S / 960 S / 1250 S

Accessori

Accessories / Optional / Accesorios



Best 700 S / Best 960 S



Best 700 S



00015101 Ø 565 x 4,5 x 30 mm, Z=96

Capacità di taglio

Cutting diagram / Capacité de coupe / Capacidad de corte

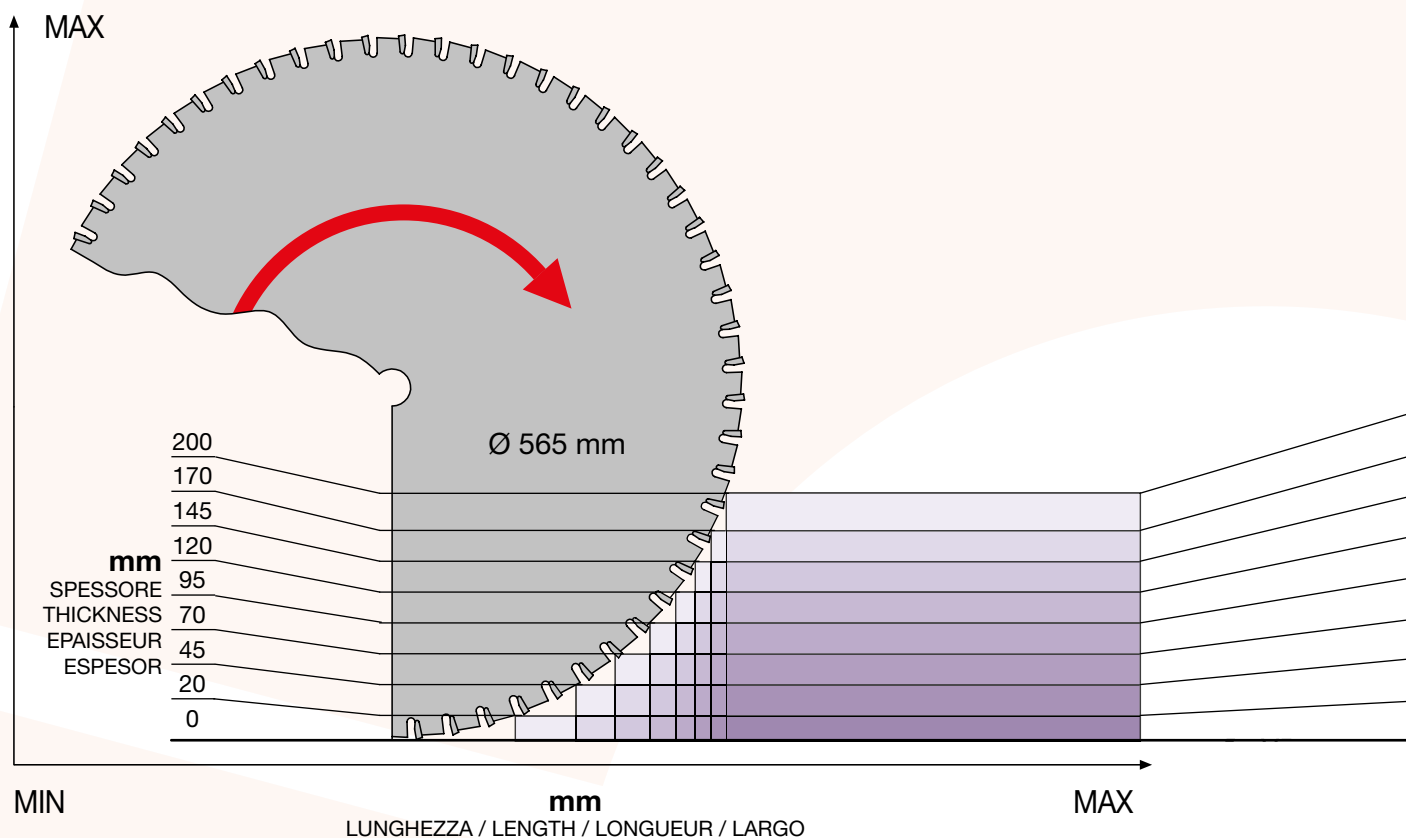
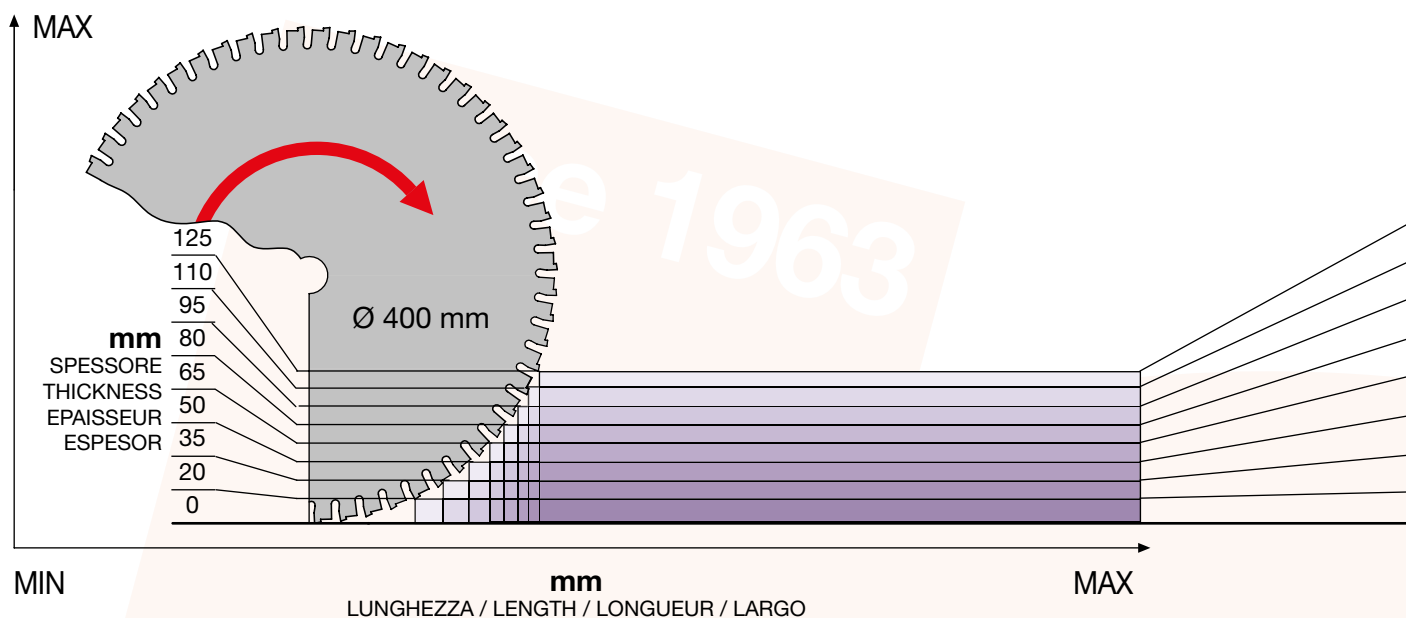

LUNGHEZZA / LENGTH / LONGUEUR / LARGO

Junior 640			Big 800			Best 960			Best 1250		
90°	45° SX	45° DX	90°	45° SX	45° DX	90°	45° SX	45° DX	90°	45° SX	45° DX
mm	mm	mm	mm	mm	mm	mm	mm	mm	mm	mm	mm
450	125	315	610	240	430	770	350	565	1060	555	745
456			616			776			1066		
464			624			784			1074		
474			634			794			1084		
486			646			806			1096		
501			661			821			1111		
520			680			840			1130		
545	190	380	705	310	500	865	425	615	1155	610	800

LUNGHEZZA / LENGTH / LONGUEUR / LARGO

Best 700 S			Best 960 S			Best 1250 S					
90°	45° SX	45° DX	90°	45° SX	45° DX	90°	445° SX	45° DX			
mm	mm	mm	mm	mm	mm	mm	mm	mm			
400	270	80	680	470	280	970	675	385			
411			691			981					
424			704			994					
440			720			1010					
460			740			1030					
486			766			1056					
520			800			1090					
570	210	400	850	400	590	1140	595	785			

EC VERSION

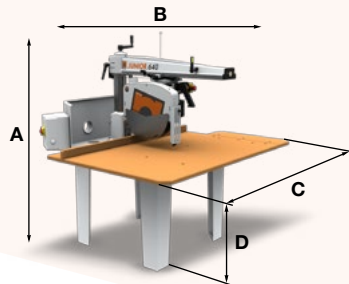
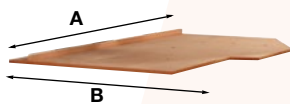
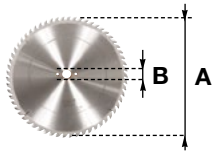

	Junior 640	Big 800	Best 960
	A Ø 400 mm B Ø 30 mm	A Ø 400 mm B Ø 30 mm	A Ø 400 mm B Ø 30 mm
	HP 4 kW 3 3PH 2800 RPM	HP 4 kW 3 3PH 2800 RPM	HP 4 kW 3 3PH 2800 RPM
	Ø 60 mm	Ø 60 mm	Ø 60 mm
	Ø 100 mm	Ø 100 mm	Ø 100 mm
	A 1580 mm B 975 mm	A 1860 mm B 1145 mm	A 2000 mm B 1355 mm
	0 - 860 mm	0 - 1030 mm	0 - 1150 mm
	0 - 45 mm	0 - 45 mm	0 - 150 mm
	0 - 80 mm	0 - 80 mm	0 - 80 mm
	A 1550 mm B 1400 mm C 1580 mm D 800 mm	A 1550 mm B 1570 mm C 1860 mm D 800 mm	A 1680 mm B 1820 mm C 2000 mm D 800 mm
	1600 x 850 x 660 mm 203 kg 215 kg	1900 x 850 x 660 mm 225 kg 237 kg	2000 x 1000 x 670 mm 294 kg 306 kg

Best 1250	Best 700 S	Best 960 S	Best 1250 S
A Ø 400 mm B Ø 30 mm	A Ø 565 mm B Ø 30 mm	A Ø 565 mm B Ø 30 mm	A Ø 565 mm B Ø 30 mm
HP 4 kW 3 3PH 2800 RPM	HP 7,5 kW 5,5 3PH 2800 RPM	HP 7,5 kW 5,5 3PH 2800 RPM	HP 7,5 kW 5,5 3PH 2800 RPM
Ø 60 mm	Ø 60 mm	Ø 60 mm	Ø 60 mm
Ø 100 mm	Ø 100 mm	Ø 100 mm	Ø 100 mm
A 2400 mm B 1580 mm	A 1700 mm B 1095 mm	A 2000 mm B 1355 mm	A 2400 mm B 1580 mm
0 - 1440 mm			
0 - 150 mm	0 - 40 mm	0 - 40 mm	0 - 40 mm
0 - 80 mm	0 - 135 mm	0 - 135 mm	0 - 135 mm
A 1680 mm B 1940 mm C 2400 mm D 800 mm	A 1680 mm B 1560 mm C 1700 mm D 800 mm	A 1680 mm B 1820 mm C 2000 mm D 800 mm	A 1680 mm B 1940 mm C 2400 mm D 800 mm
2400 x 1050 x 700 mm 344 kg 362 kg	1700 x 1000 x 1200 mm 298 kg 310 kg	2000 x 1000 x 1200 mm 311 kg 326 kg	2400 x 1050 x 1230 mm 364 kg 382 kg

Junior 640 / Big 800

STANDARD VERSION

since 1963



Best 960 / Best 1250

STANDARD VERSION



Capacità di taglio

Cutting diagram / Capacité de coupe / Capacidad de corte

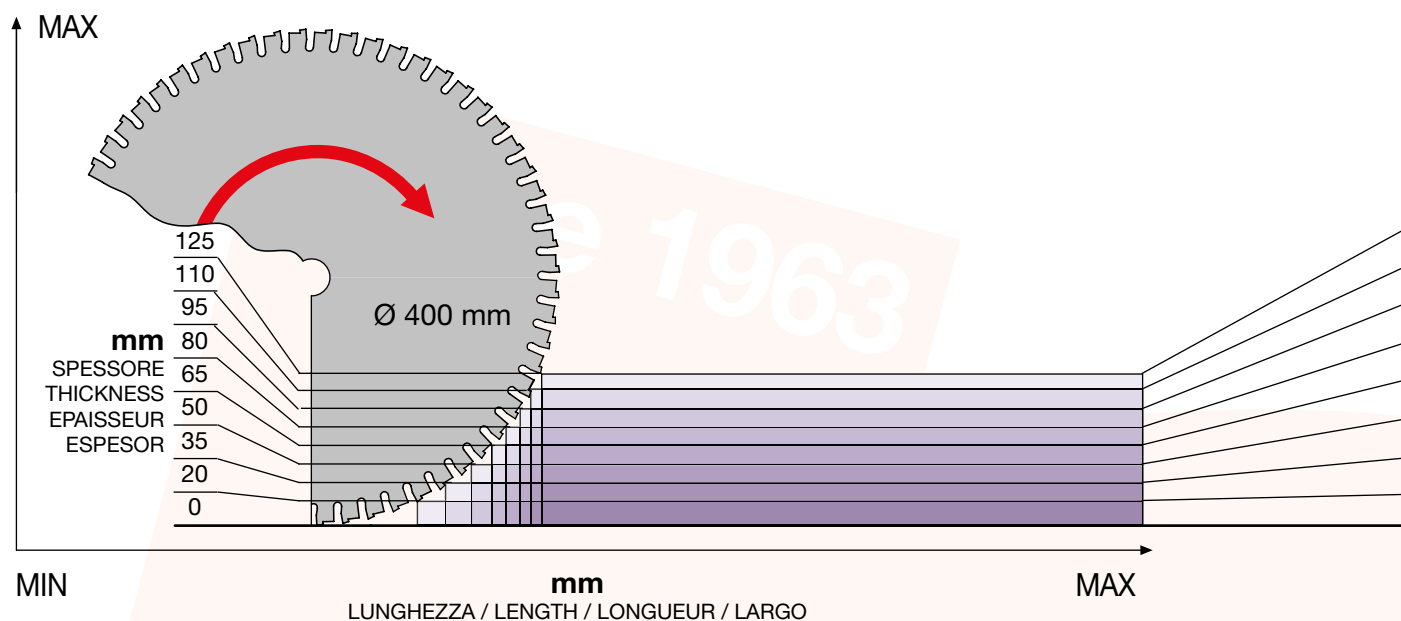

STANDARD VERSION

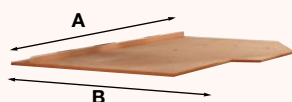
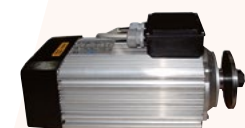
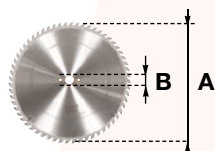

	Junior 640	Big 800	Best 960	Best 1250
	A Ø 400 mm B Ø 30 mm	A Ø 400 mm B Ø 30 mm	A Ø 400 mm B Ø 30 mm	
	HP 4 kW 3 3PH 2800 RPM	HP 4 kW 3 3PH 2800 RPM	HP 4 kW 3 3PH 2800 RPM	HP 4 kW 3 3PH 2800 RPM
	Ø 60 mm	Ø 60 mm	Ø 60 mm	Ø 60 mm
	A 1100 mm B 880 mm	A 1200 mm B 950 mm	A 1200 mm B 1100 mm	A 2400 mm B 1580 mm
	0 - 860 mm	0 - 1030 mm	0 - 1150 mm	0 - 1440 mm

LUNGHEZZA / LENGTH / LONGUEUR / LARGO

Junior 640			Big 800			Best 960			Best 1250		
90°	45° SX	45° DX	90°	45° SX	45° DX	90°	45° SX	45° DX	90°	45° SX	45° DX
mm	mm	mm	mm	mm	mm	mm	mm	mm	mm	mm	mm
450	125	315	610	240	430	770	350	565	1060	555	745
456			616			776			1066		
464			624			784			1074		
474			634			794			1084		
486			646			806			1096		
501			661			821			1111		
520			680			840			1130		
545	190	380	705	310	500	865	425	615	1155	610	800

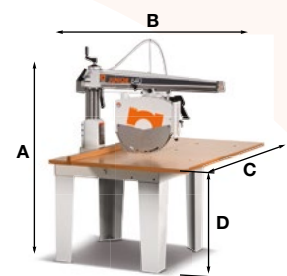
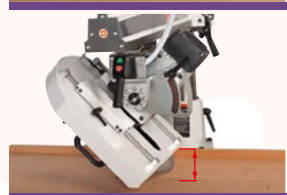

	Junior 640	Big 800	Best 960	Best 1250
0 - 45 mm	0 - 45 mm	0 - 45 mm	0 - 150 mm	0 - 150 mm
0 - 80 mm	0 - 80 mm	0 - 80 mm	0 - 80 mm	0 - 80 mm
A 1550 mm	A 1550 mm	A 1550 mm	A 1680 mm	A 1680 mm
B 1110 mm	B 1290 mm	B 1560 mm	B 1850 mm	
C 1100 mm	C 1200 mm	C 1200 mm	C 2400 mm	
D 800 mm	D 800 mm	D 800 mm	D 800 mm	
1420 x 850 x 590 mm 186 kg 198 kg	1420 x 850 x 590 mm 205 kg 217 kg	1500 x 1000 x 600 mm 272 kg 284 kg	2400 x 1050 x 700 mm 325 kg 342 kg	



maggi service

- ☎ +39 0571 635477
- 📱 +39 335 284751
- ✉ service@maggi-technology.com
- 🌐 service.maggitechnology



maggi technology
 Via delle Regioni, 297
 50053 CERTALDO (FI), ITALY
 +39 0571 63541
www.maggi-technology.com

HOUTBEWERKINGSMACHINES

AFZUIGINSTALLATIES

GEREEDSCHAPPEN



TEL. (0515) 43 15 70 - www.rando.nl - SNEEK

ONDERHOUD - REPARATIE - REVISIE