

Professional band saws, sturdy and extremely precise, for woodworking shops and craftsmen.



**Cast-iron Saw  
Wheels**  
solidity



**Blade Guide**  
perfect results



**Protection**  
safety first

# band saw operating groups

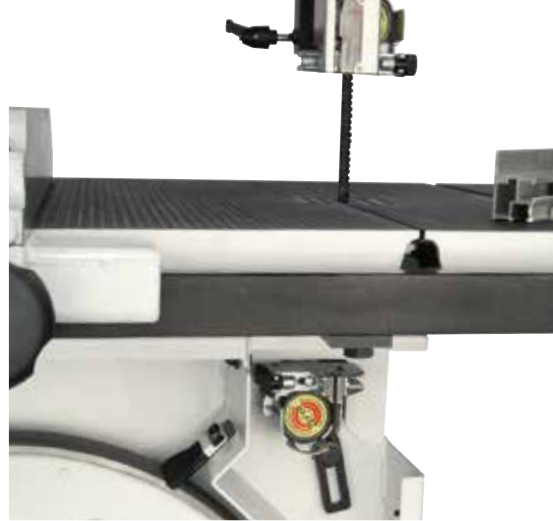

perfect results

## **Blade Guide.**

A perfect cut result is assured by the top and bottom high precision blade guides. Practical machines suitable also to perform straight and tilted cuts on wood, plastic and aluminum.



solidity and sturdiness

## **Cast Iron Saw Wheels.**

Very thick, cast iron wheels, as well as the worktable, running on sealed for life ball bearings.

safety first  
**Protections.**  
Total safety machining with telescopic protections with rackwork to the blade.



# band saw dimensions and technical data

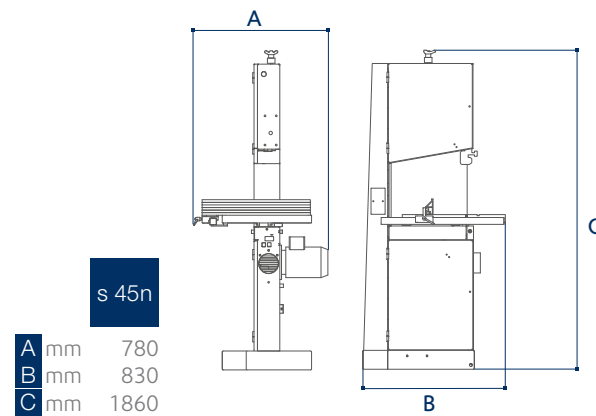

		s 45n
Work table dimensions	mm	520 x 600
Cast-iron saw wheels diameter	mm	450
Max. cutting height	mm	300
Max. cutting width	mm	440
Worktable tilting (CE)		0° ÷ 45° (20°)
Min./max. saw blade length	mm	3690 / 3742
Min./max. saw blade dimensions	mm	6 x 0,5 / 25 x 0,5
Three-phase motor power	kW/Hz	3 (3,6) / 50 (60)
Exhaust outlet diameter	mm	120
Air consumption	l/min (bar)	-