

Professional band saws, sturdy and extremely precise,  
for woodworking shops and craftsmen.



**Cast Iron Saw Wheels**  
solidity



**Blade Guide**  
perfect results

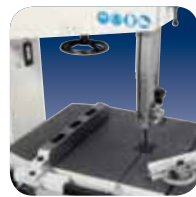

**Protections**  
safety first

# band saws operating groups

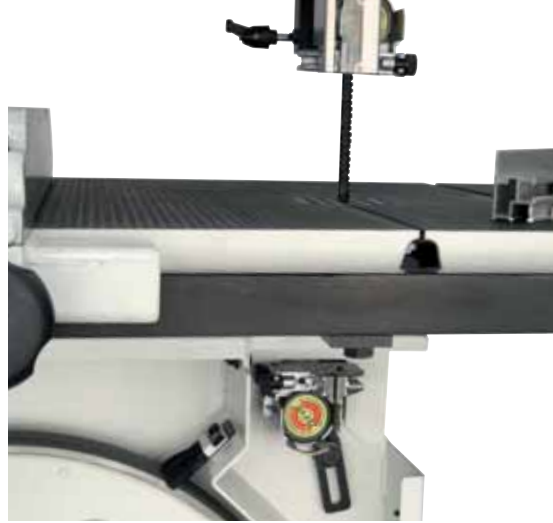

perfect results

### **Blade Guide.**

A perfect cut result is assured by the top and bottom high precision blade guides. Practical machines suitable also to perform straight and tilted cuts on wood, plastic and aluminum.



solidity and sturdiness

### **Cast Iron Saw Wheels.**

Very thick, cast iron wheels, as well as the worktable, running on sealed for life ball bearings.



safety first

### **Protections.**

Total safety machining with telescopic protections with rackwork to the blade.

# band saws dimensions and technical data

	s 45n	s 400p	s 500p	s 600p	s 700p	s 800p	s 900p
A mm	780	610	700	760	880	945	955
B mm	830	830	940	1165	1415	1620	1740
C mm	1860	1915	2060	2075	2300	2495	2705

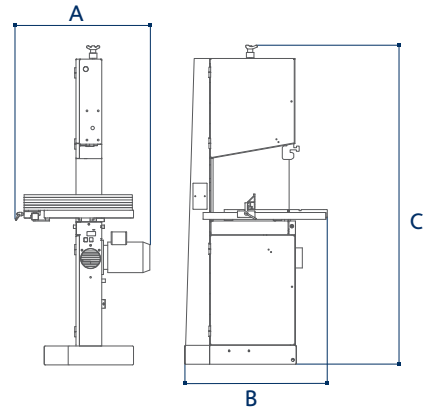

		s 45n	s 400p	s 500p	s 600p	s 700p	s 800p	s 900p
Worktable dimensions	mm	520 x 600	450 x 600	500 x 700	580 x 810	710 x 1030	800 x 1170	800 x 1170
Cast iron saw wheels diameter	mm	450	400	500	600	700	800	900
Max. cutting height	mm	300	400	500	360	435	500	550
Max. cutting width	mm	440	380	480	580	680	780	880
Worktable tilting (CE)		0° ÷ 45° (20°)	0° ÷ 45° (20°)	0° ÷ 45° (20°)	0° ÷ 45° (20°)	0° ÷ 45° (20°)	0° ÷ 45° (20°)	0° ÷ 45° (20°)
Min./max. saw blade length	mm	3690 / 3742	3835 / 3910	4296 / 4376	4480 / 4580	5040 / 5180	5540 / 5670	6100 / 6300
Min./max. blade dimensions	mm	6 x 0,5 / 25 x 0,5	10 x 0,5 / 30 x 0,5	10 x 0,5 / 30 x 0,5	10 x 0,6 / 35 x 0,6	10 x 0,6 / 40 x 0,6	10 x 0,7 / 45 x 0,7	10 x 0,8 / 50 x 0,8
Three phase motor starting from	kW/Hz	3 (3,6) / 50 (60)	1,5 (1,8) / 50 (60)	2,2 (2,7) / 50 (60)	2,2 (2,7) / 50 (60)	3 (3,6) / 50 (60)	4 (4,8) / 50 (60)	5,5 (6,6) / 50 (60)
Exhaust outlet diameter	mm	120	100	100	100	100	120	120
Air consumption	l/min (bar)	-	-	-	-	-	0,027 (6)	0,027 (6)