

# band saws

Professional band saws, sturdy and extremely precise, for woodworking shops and craftsmen.

- formula s 400p
- formula s 500p
- formula s 600p
- formula s 700p
- formula s 800p
- formula s 900p

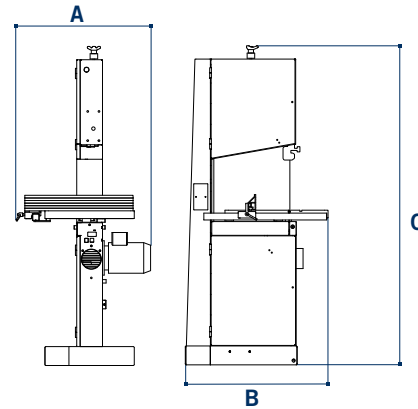

	s 400p	s 500p	s 600p	s 700p	s 800p
A mm	610	700	760	880	945
B mm	830	940	1165	1415	1620
C mm	1915	2060	2075	2300	2495



formula		s 900p	s 800p	s 700p	s 600p	s 500p	s 400p
Work table dimensions	mm	800 x 1170	800 x 1170	710 x 1030	580 x 810	500 x 700	450 x 600
Cast-iron saw wheels diameter	mm	900	800	700	600	500	400
Max. cutting height	mm	570	520	460	370	500	400
Max. cutting width	mm	880	780	680	580	480	380
Work table tilting (CE)	mm	0° ÷ 45° (20°)	0° ÷ 45° (20°)	0° ÷ 45° (20°)	0° ÷ 45° (20°)	0° ÷ 45° (20°)	0° ÷ 45° (20°)
Min./max. blade length	mm	6100/6300	5540/5670	5040/5180	4480/4580	4296/4376	3835/3910
Min./max. blade dimensions	mm	10x0,8 / 50x0,8	10x0,7 / 45x0,7	10x0,6 / 40x0,6	10x0,6 / 35 x0,6	10 x 0,5/30 x 0,5	10 x 0,5/30 x 0,5
Three-phase motor power starting from	kW/Hz	5,5 (6,6) / 50 (60)	4 (4,8) / 50 (60)	3 (3,6) / 50 (60)	2,2 (2,7) / 50 (60)	2,2 (2,7) / 50 (60)	1,5 (1,8) / 50 (60)
Exhaust outlet diameter	l/mm(bar)	120	120	100	100	100	100
Air consumption	l/mm(bar)	0,027 (6)	0,027 (6)	-	-	-	-

band  
saws  
operating  
groups



Perfect results

**Blade guide.**

A perfect cut result is assured by the top and bottom high precision blade guides. Practical machines suitable also to perform straight and tilted cuts on wood, plastic and aluminum.



Safety first

**Protections.**

Total safety machining with telescopic protections with rackwork to the blade.



Solidity and sturdiness

**Cast iron saw wheels.**

Very thick, cast iron wheels, as well as the worktable, running on sealed for life ball bearings.